

WARNING! - Please Read this Information Carefully:

The project described in these pages utilizes **POTENTIALLY FATAL HIGH VOLTAGES**. If you are in any way unfamiliar with high voltage circuits or are uncomfortable working around high voltages, **PLEASE DO NOT RISK YOUR LIFE BY BUILDING THEM**. Seek help from a competent technician before building any unfamiliar electronics circuit. While efforts are made to ensure accuracy of these circuits, no guarantee is provided, of any kind!

USE AT YOUR OWN RISK: THE WEBMASTER, PROJECT COORDINATOR, PROJECT CONTRIBUTORS AND WEB SPACE PROVIDER EXPRESSLY DISCLAIM ALL LIABILITY FOR INJURY OR PROPERTY DAMAGE RESULTING FROM THIS INFORMATION! ALL INFORMATION IS PROVIDED 'AS-IS' AND WITHOUT WARRANTY OF ANY KIND.

NOTICE! - This document represents a project that is in the PRELIMINARY, or BETA TEST phase.

This project is intended for **experienced builders only** at this phase. It may contain errors on the documents, or in the design itself. Once this project has been successfully prototyped and tested this notice will be removed and it will be released for construction. Should you find an error on the documents, please notify the Project Coordinator so that the documents may be corrected.

COPYRIGHT AND INTELLECTUAL PROPERTY NOTICE:

The content of this document is protected by the copyright laws of the United States of America and the international copyright laws and agreements.

Except where specifically noted, Cliff Chappell or Chris Hurley owns (or has permission to use) all intellectual property rights in relation to this document and its content (including, but not limited to, all trademarks and copyright).

No part of the document may be reproduced, displayed, copied, translated, adapted, downloaded, broadcast, used or republished in any form including (without limitation) distribution, or storage in a system for retrieval.

Revision	Description
09.12.24	Ready For Prototyping

① TWO 0.0033uF CAPACITORS MAY BE PLACED IN SERIES IF YOU ARE UNABLE TO SOURCE A SINGLE 0.0015uF CAPACITOR.

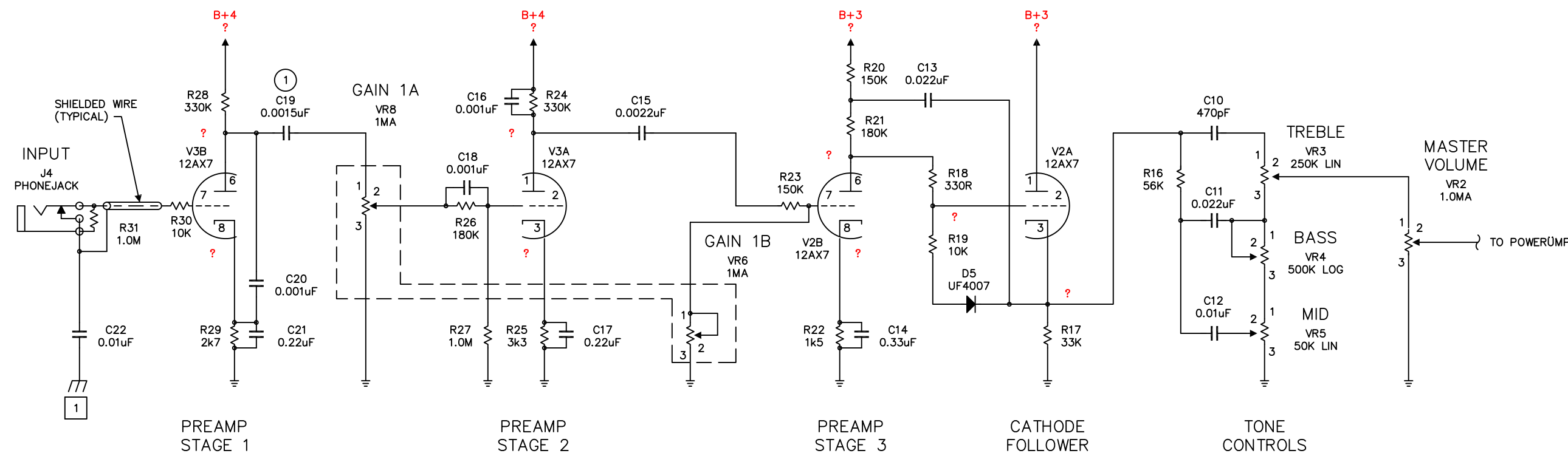

01 - ÜberSEL Preamp Schematic

Revision	Description
09.12.24	Ready For Prototyping

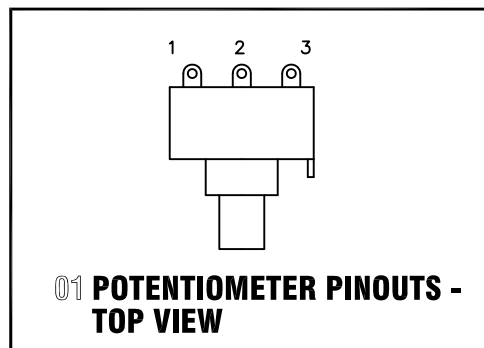

GENERAL NOTES:

1. ALL RESISTORS 1/2W MINIMUM UNLESS OTHERWISE NOTED.
2. ALL COUPLING CAPACITORS 400V OR GREATER.
3. C1 SHOULD BE A OIL FILLED MOTOR RUN CAPACITOR RATED FOR AT LEAST 370VAC. C2, C4, C5, AND C6 SHOULD BE FILM CAPACITORS.
4. CARE SHOULD BE TAKEN TO INSURE THAT THE BUL-390D TRANSISTOR DOES NOT COME INTO DIRECT CONTACT WITH THE CHASSIS. HEAT SINKING OF THE TRANSISTOR MAY BE NECESSARY.
5. SHIELDED WIRE, AS WELL AS THE SHIELD'S TIE TO GROUND, IS SHOWN IN THIS MANNER ON THE SCHEMATIC:

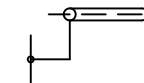

CONSTRUCTION NOTES:

1. THIS IS A GROUND CONNECTION TO THE CHASSIS. THE MAINS SAFETY CONNECTION SHOULD BE MADE AS CLOSE AS POSSIBLE TO THE POINT WHERE AC ENTERS THE CHASSIS. THE CIRCUIT CONNECTION SHOULD BE MADE AS CLOSE AS POSSIBLE TO THE INPUT JACK. IDEALLY, THE JACK ITSELF SHOULD BE USED AS THE CONNECTION POINT BY NOT ISOLATING IT FROM THE CHASSIS.