

WARNING! - Please Read this Information Carefully:

The project described in these pages utilizes **POTENTIALLY FATAL HIGH VOLTAGES**. If you are in any way unfamiliar with high voltage circuits or are uncomfortable working around high voltages, **PLEASE DO NOT RISK YOUR LIFE BY BUILDING THEM**. Seek help from a competent technician before building any unfamiliar electronics circuit. While efforts are made to ensure accuracy of these circuits, no guarantee is provided, of any kind!

USE AT YOUR OWN RISK: THE WEBMASTER, PROJECT COORDINATOR, PROJECT CONTRIBUTORS AND WEB SPACE PROVIDER EXPRESSLY DISCLAIM ALL LIABILITY FOR INJURY OR PROPERTY DAMAGE RESULTING FROM THIS INFORMATION! ALL INFORMATION IS PROVIDED 'AS-IS' AND WITHOUT WARRANTY OF ANY KIND.

COPYRIGHT AND INTELLECTUAL PROPERTY NOTICE:

The content of this document is protected by the copyright laws of the United States of America and the international copyright laws and agreements.

Except where specifically noted, Cliff Chappell or Chris Hurley owns (or has permission to use) all intellectual property rights in relation to this document and its content (including, but not limited to, all trademarks and copyright).

No part of the document may be reproduced, displayed, copied, translated, adapted, downloaded, broadcast, used or republished in any form including (without limitation) distribution, or storage in a system for retrieval.

CAPACITOR, DIODE, RESISTOR, POT. AND TUBE NUMBERING NOTE:

GAPS HAVE BEEN LEFT IN THE CAPACITOR, DIODE, RESISTOR, POTENTIOMETER, AND TUBE NUMBERING IN ORDER TO MAINTAIN CONSISTENCY BETWEEN THE P1, HIGH OCTANE, AND P1 EXTREME AMPS. A MISSING COMPONENT INDICATES THAT IT IS NOT USED ON THAT AMP, BUT IS USED ON ANOTHER.

RADIO NOISE NOTE:

IN THE UNLIKELY EVENT YOUR AMP STARTS PICKING UP RADIO STATIONS, YOU CAN INSTALL A GRID RESISTOR ON PIN 7 OF V4B. THE VALUE SHOULD BE BETWEEN 10K AND 68K. THE HIGHER THE VALUE, THE LESS RADIO NOISE AND THE LOWER THE VALUE, THE LESS POWER SUPPLY NOISE.

| Revision | Description |
|----------|--------------------------------------------------------------------------------------------------------------------------------------------------------------------------------------------------------------------------------------------------------------------------------------------------------------------------------------------------------------------------------------------------|
| 08.03.13 | Renumbered Components Removed 1st Stage Grid Resistor Changed C15 To 0.68uF And R21 To 2.7K Changed R17-18 To 220K & C13 To 0.001uF Changed VR6 To 500K LOG Changed R18 To 1.2K Changed R9 To 56K Changed C8 To 0.01uF Changed VR3 To 500K LOG Changed VR4 To 50K LIN Added R5 Removed Parallel Octal Socket Changed D1 & D2 To UF4007 Changed R8 To 130R |
| 08.04.10 | Renumbered Components |
| 08.05.07 | Added Voltage Readings |
| 09.11.25 | Missing Chassis Components - PDF Rebuild |

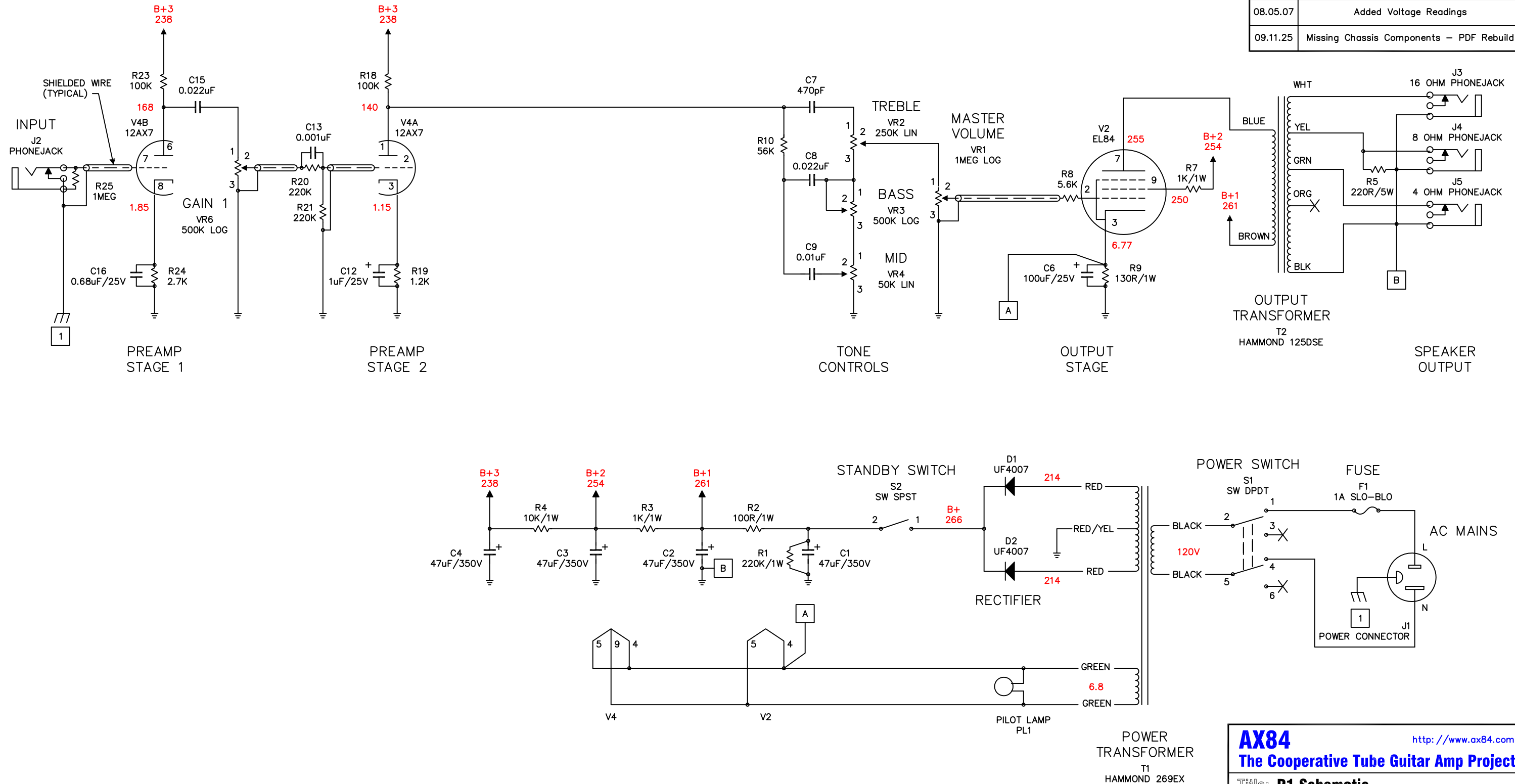

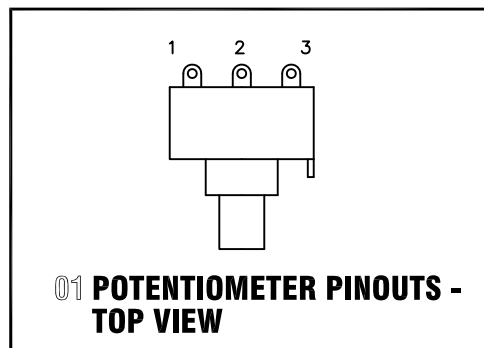

| Revision | Description |
|----------|--------------------------------------------------------------------------------------------------------------------------------------------------------------------------------------------------------------------------------------------------------------------------------------------------------------------------------------------------------------------------------------------------|
| 08.03.13 | Renumbered Components Removed 1st Stage Grid Resistor Changed C15 To 0.68uF And R21 To 2.7K Changed R17-18 To 220K & C13 To 0.001uF Changed VR6 To 500K LOG Changed R18 To 1.2K Changed R9 To 56K Changed C8 To 0.01uF Changed VR3 To 500K LOG Changed VR4 To 50K LIN Added R5 Removed Parallel Octal Socket Changed D1 & D2 To UF4007 Changed R8 To 130R |
| 08.04.10 | Renumbered Components |
| 08.05.07 | Added Voltage Readings |
| 09.11.25 | Missing Chassis Components – PDF Rebuild |

GENERAL NOTES:

- ALL RESISTORS 1/2W MINIMUM UNLESS OTHERWISE NOTED.
- ALL COUPLING CAPACITORS 250V OR GREATER.
- 47uF/350V ELECTROLYTIC POWER SUPPLY CAPACITOR VALUES/VOLTAGES ARE NOT CRITICAL. SUGGESTED VALUES: 20-50uF AT 350-500V.
- THE HAMMOND 269EX POWER TRANSFORMER IS USED IN THIS AMP. IT MAY BE REPLACED BY UNITS WITH THE FOLLOWING SPECIFICATIONS:

180-0-180V @ 65mA OR MORE SECONDARY B+ TAPS
6.3V @ 2.5A OR MORE FILAMENT TAPS
- THE HAMMOND 125DSE OUTPUT TRANSFORMER IS USED IN THIS AMP. IT MAY BE REPLACED BY UNITS WITH THE FOLLOWING SPECIFICATIONS:

SINGLE-ENDED OUTPUT
4000-5000 OHM PRIMARY IMPEDENCE
70mA OR MORE MAXIMUM D.C. BIAS
4, 8, AND 16 OHM SECONDARY TAPS
- SHIELDED WIRE, AS WELL AS THE SHIELD'S TIE TO GROUND, IS SHOWN IN THIS MANNER ON THE SCHEMATIC:

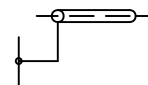
- IF YOU HAVE MAINS VOLTAGES OF 200VAC OR ABOVE, YOU SHOULD USE HAMMOND'S 3XX SERIES TRANSFORMERS INSTEAD OF THE 2XX SERIES SHOWN. THE 369EX SHOULD REPLACE THE 269EX, THE 370DX REPLACES THE 270DX, AND THE 370EX REPLACES THE 270DX.

CONSTRUCTION NOTES:

- THIS IS A GROUND CONNECTION TO THE CHASSIS. THE MAINS SAFETY CONNECTION SHOULD BE MADE AS CLOSE AS POSSIBLE TO THE POINT WHERE AC ENTERS THE CHASSIS. THE CIRCUIT CONNECTION SHOULD BE MADE AS CLOSE AS POSSIBLE TO THE INPUT JACK. IDEALLY, THE JACK ITSELF SHOULD BE USED AS THE CONNECTION POINT BY NOT ISOLATING IT FROM THE CHASSIS.

AX84 P1 Amplifier BOM

Revision: 09.11.25

NOTE: Parts for options are not included on this bill of materials.

| Item | Quantity | Reference | Value |
|------|----------|-----------------------------------|----------------------------------------|
| 1 | 4 | C1, C2, C3, C4 | 47uF/350V |
| 2 | 0 | C5 | Not Used |
| 3 | 1 | C6 | 100uF/25V |
| 4 | 1 | C7 | 470pF |
| 5 | 2 | C8, C15 | 0.022uF |
| 6 | 1 | C9 | 0.01uF |
| 7 | 0 | C10, C11 | Not Used |
| 8 | 1 | C12 | 1uF/25V |
| 9 | 1 | C13 | 0.001uF |
| 10 | 0 | C14 | Not Used |
| 11 | 1 | C16 | 0.68uF/25V |
| 12 | 1 | R1 | 220K/1W |
| 13 | 1 | R2 | 100R/1W |
| 14 | 2 | R3, R7 | 1K/1W |
| 15 | 1 | R4 | 10K/1W |
| 16 | 1 | R5 | 220R/5W |
| 17 | 0 | R6 | Not Used |
| 18 | 1 | R8 | 5.6K |
| 19 | 1 | R9 | 130R/1W |
| 20 | 1 | R10 | 56K |
| 21 | 0 | R11, R12, R13, R14, R15, R16, R17 | Not Used |
| 22 | 2 | R18, R23 | 100K |
| 23 | 1 | R19 | 1.2K |
| 24 | 2 | R20, R21 | 220K |
| 25 | 0 | R22 | Not Used |
| 26 | 1 | R24 | 2.7K |
| 27 | 1 | R25 | 1 Meg |
| 28 | 1 | F1 | 1A SLO-BLO |
| 29 | 1 | FH1 | Fuse Holder |
| 30 | 1 | J1 | Power Connector |
| 31 | 4 | J2, J3, J4, J5 | Phonejack |
| 32 | 4 | JW1, JW2, JW3, JW4 | Phonejack Isolation Washer (if needed) |
| 33 | 1 | S1 | SW DPDT |
| 34 | 1 | S2 | SW SPST |
| 35 | 2 | D1, D2 | UF4007 |
| 36 | 1 | PL1 | Pilot Lamp Assembly And Bulb |
| 37 | 1 | T1 | Hammond 269EX |
| 38 | 1 | T2 | Hammond 125DSE |
| 39 | 2 | SK2, SK4 | 9 Pin Tube Sockets |
| 40 | 1 | V2 | EL84 |
| 41 | 1 | V4 | 12AX7 |
| 42 | 1 | VR1 | 1Meg LOG |
| 43 | 1 | VR2 | 250K LIN |
| 44 | 2 | VR3, VR6 | 500K LOG |
| 45 | 1 | VR4 | 50K LIN |

| | | | |
|----|---|--------------------|---------|
| 46 | 5 | K1, K2, K3, K4, K6 | Knobs |
| 47 | 1 | CH1 | Chassis |

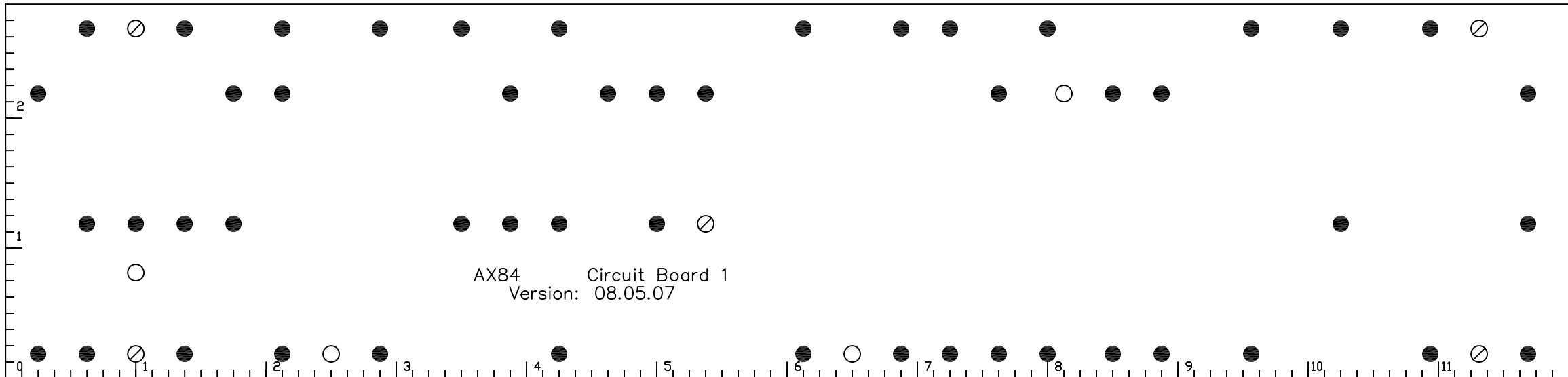

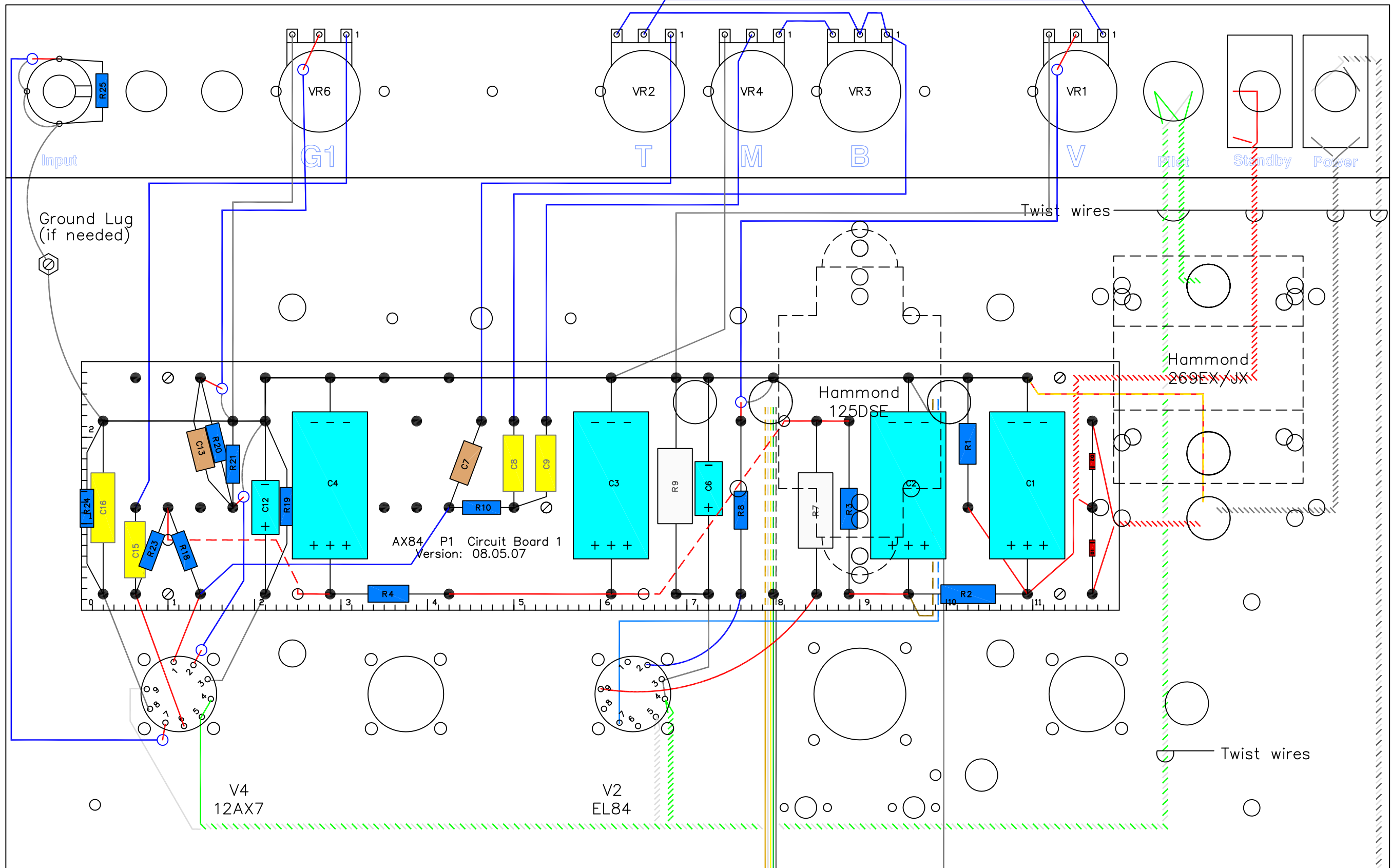

AX84 P1 Chassis Layout

Version: 09.11.25

AX84 Kit Chassis 1

Version: 08.05.07

