

WARNING! - Please Read this Information Carefully:

The project described in these pages utilizes **POTENTIALLY FATAL HIGH VOLTAGES**. If you are in any way unfamiliar with high voltage circuits or are uncomfortable working around high voltages, **PLEASE DO NOT RISK YOUR LIFE BY BUILDING THEM**. Seek help from a competent technician before building any unfamiliar electronics circuit. While efforts are made to ensure accuracy of these circuits, no guarantee is provided, of any kind!

USE AT YOUR OWN RISK: THE WEBMASTER, PROJECT COORDINATOR, PROJECT CONTRIBUTORS AND WEB SPACE PROVIDER EXPRESSLY DISCLAIM ALL LIABILITY FOR INJURY OR PROPERTY DAMAGE RESULTING FROM THIS INFORMATION! ALL INFORMATION IS PROVIDED 'AS-IS' AND WITHOUT WARRANTY OF ANY KIND.

COPYRIGHT AND INTELLECTUAL PROPERTY NOTICE:

The content of this document is protected by the copyright laws of the United States of America and the international copyright laws and agreements.

Except where specifically noted, Cliff Chappell or Chris Hurley owns (or has permission to use) all intellectual property rights in relation to this document and its content (including, but not limited to, all trademarks and copyright).

No part of the document may be reproduced, displayed, copied, translated, adapted, downloaded, broadcast, used or republished in any form including (without limitation) distribution, or storage in a system for retrieval.

Revision	Description
09.05.26	Corrected R20 And R21 Labels
10.01.28	Changed T1, L1, And T2 Added Optional FX Loop Added Optional 2nd Power Tube Option Added Quad Bias Option Renumbered Components For New Options
10.03.22	Updated Voltage Readings
10.03.25	Corrected Bass Control Wiring

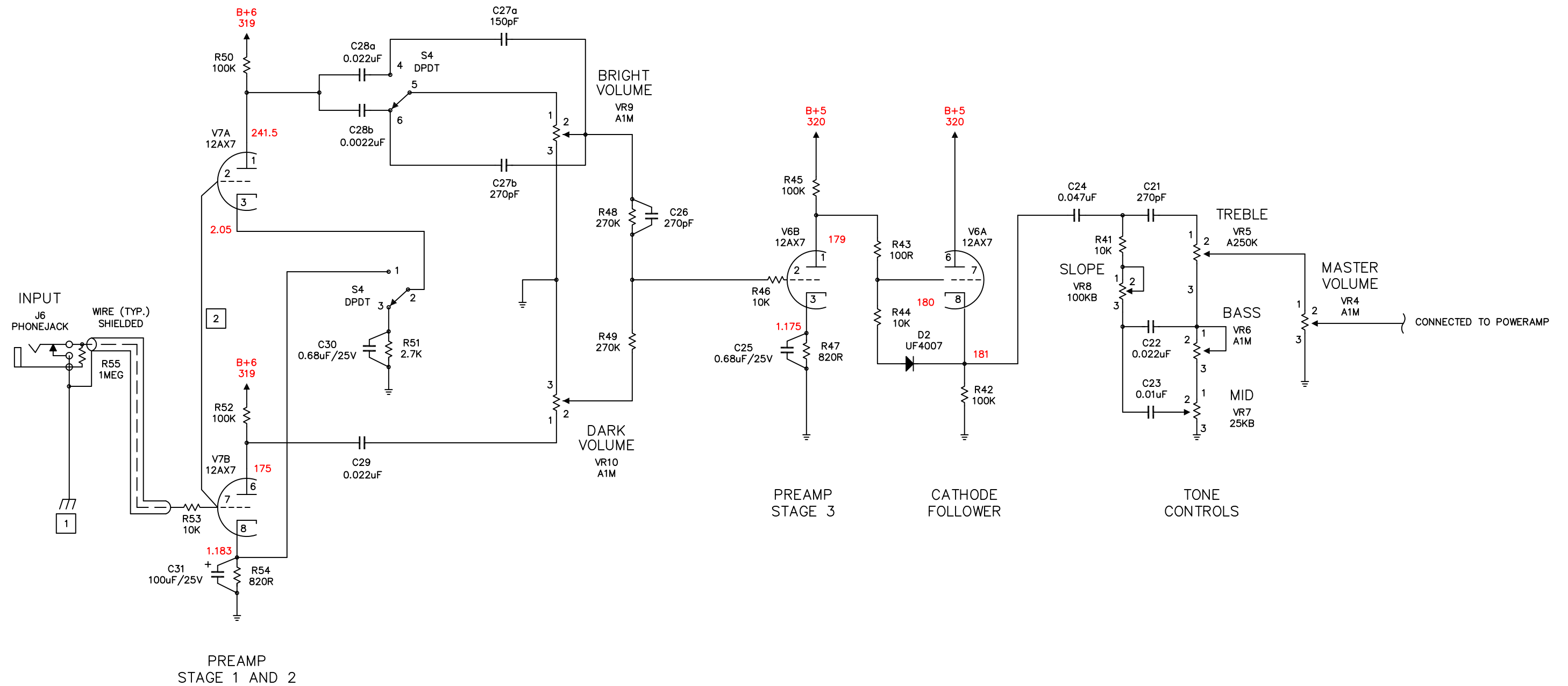

Revision	Description
09.05.26	Corrected R20 And R21 Labels
10.01.28	Changed T1, L1, And T2 Added Optional FX Loop Added Optional 2nd Power Tube Option Added Quad Bias Option Renumbered Components For New Options
10.03.22	Updated Voltage Readings
10.03.25	Corrected Bass Control Wiring

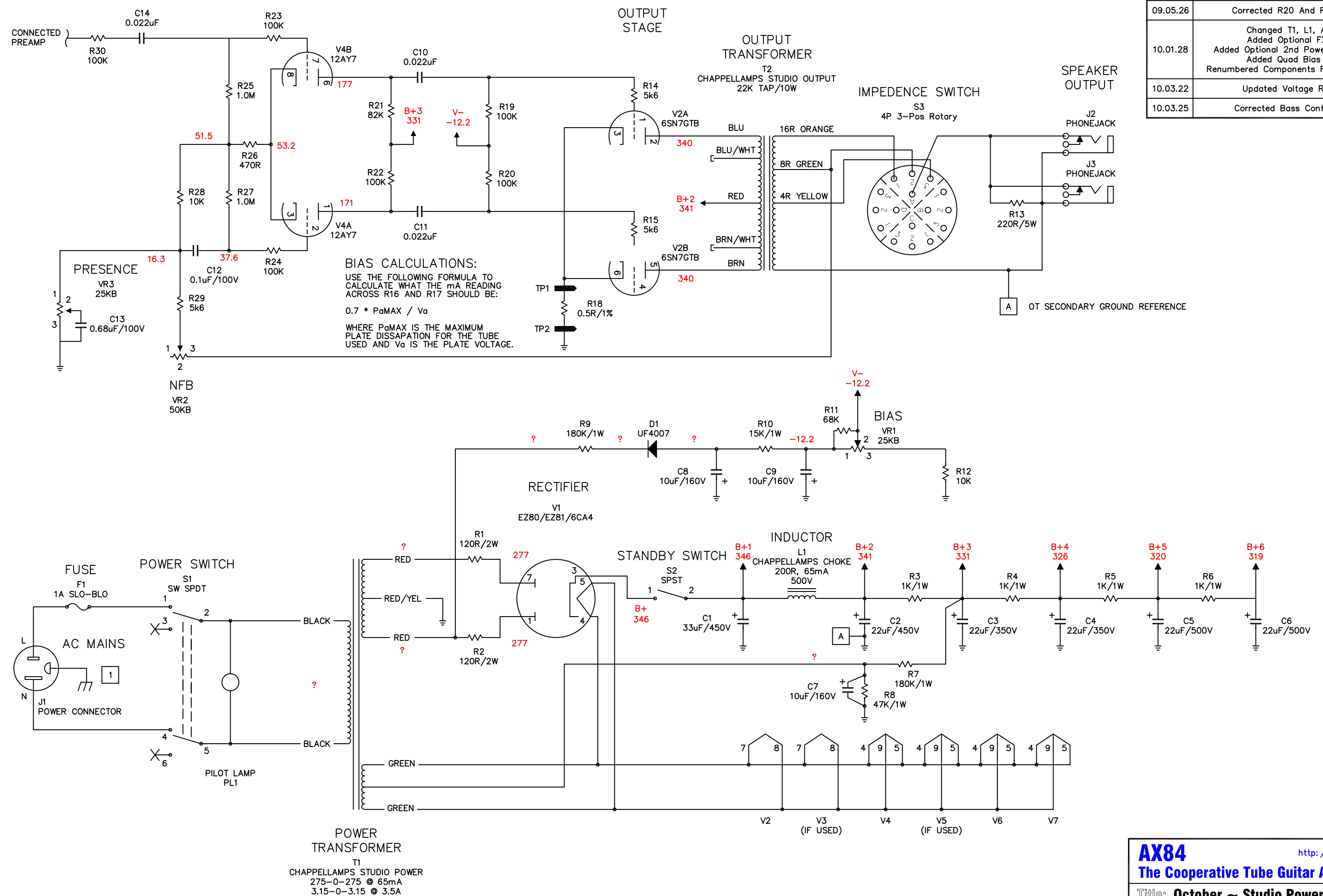

BIAS CALCULATIONS:
 USE THE FOLLOWING FORMULA TO CALCULATE WHAT THE mA READING ACROSS R16 AND R17 SHOULD BE:
 $0.7 * P_{aMAX} / V_a$
 WHERE P_{aMAX} IS THE MAXIMUM PLATE DISSIPATION FOR THE TUBE USED AND V_a IS THE PLATE VOLTAGE.

Revision	Description
09.05.26	Corrected R20 And R21 Labels
10.01.28	Changed T1, L1, And T2 Added Optional FX Loop Added Optional 2nd Power Tube Option Added Quad Bias Option Renumbered Components For New Options
10.03.22	Updated Voltage Readings
10.03.25	Corrected Bass Control Wiring

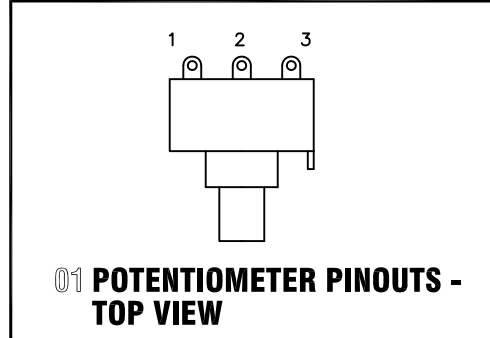

01 POTENTIOMETER PINOUTS - TOP VIEW

- GENERAL NOTES:
1. ALL RESISTORS 1/2W MINIMUM UNLESS OTHERWISE NOTED.
 2. ALL COUPLING CAPACITORS 400V OR GREATER.

- CONSTRUCTION NOTES:
1. THIS IS A GROUND CONNECTION TO THE CHASSIS. THE MAINS SAFETY CONNECTION SHOULD BE MADE AS CLOSE AS POSSIBLE TO THE POINT WHERE AC ENTERS THE CHASSIS. THE CIRCUIT CONNECTION SHOULD BE MADE AS CLOSE AS POSSIBLE TO THE INPUT JACK. IDEALLY, THE JACK ITSELF SHOULD BE USED AS THE CONNECTION POINT BY NOT ISOLATING IT FROM THE CHASSIS.

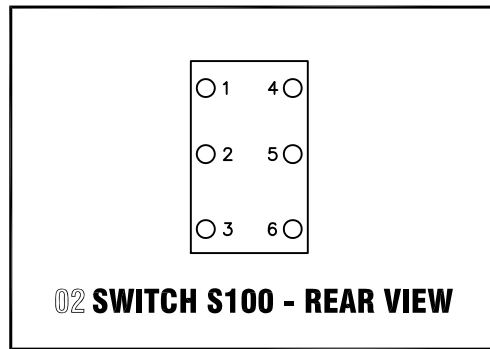

02 SWITCH S100 - REAR VIEW

- VOLTAGE READING NOTES:
1. DIFFERENT TUBES DRAW DIFFERENT AMOUNTS OF CURRENT, NO TWO ARE ALIKE UNLESS THEY ARE MATCHED. THE AMOUNT OF CURRENT DRAWN BY ALL THE TUBES IN THE AMP WILL AFFECT VOLTAGE READINGS THROUGHOUT THE AMP.
 2. INSTALLING THE QUAD POWER TUBE OPTION AND/OR THE FX LOOP OPTION WILL CAUSE THE VOLTAGES IN YOUR AMP TO BE LOWER THAN THOSE SHOWN ON THE MAIN SCHEMATIC.

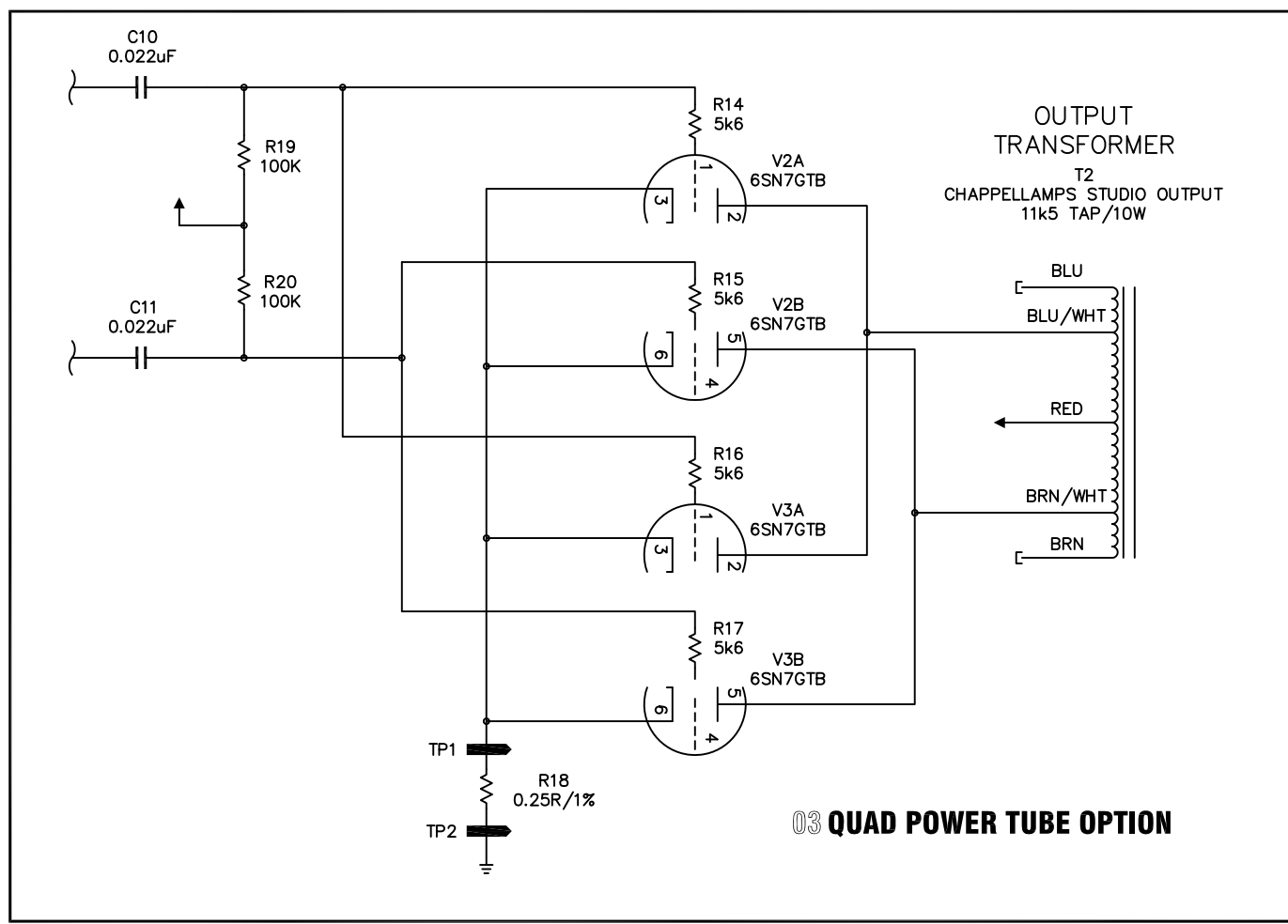

03 QUAD POWER TUBE OPTION

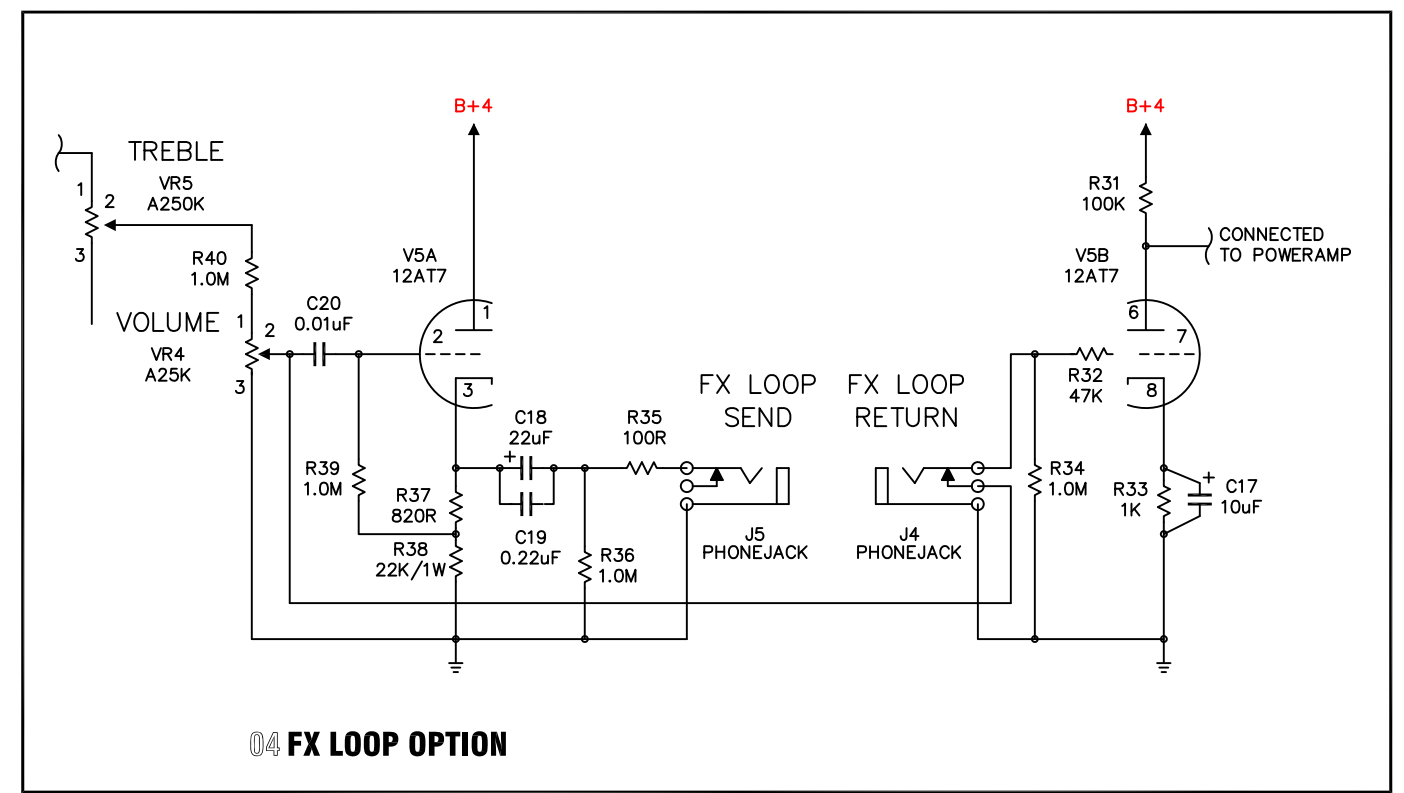

04 FX LOOP OPTION

AX84 October Studio Amplifier BOM

Revision: 10.03.25

Item	Quantity	Reference	Value
1	1	C1	33uF/450V (axial)
2	1	C2	22uF/450V (axial)
3	4	C3, C4, C, C6	22uF/350V (1 axial & 3 radial)
4	3	C7, C8, C9	10uF/160V
5	7	C10, C11, C14, C22, C28a, C29	0.022uF/400V
6	1	C12	0.1uF/100V
7	3	C13, C25, C30	0.68uF/100V
8	3	C21, C26, C27b	270pF/500V
9	1	C23	0.01uF/400V
10	1	C24	0.047uF/400V
11	1	C27a	150pF/500V
12	1	C28b	0.0022uF/400V
13	1	C31	100uF/25V
14	2	R1, R2	120R/2W
15	4	R3, R4, R5, R6	1K/1W
16	2	R7, R9	180K/1W
17	1	R8	47K/1W
18	1	R10	15K/1W
19	1	R11	68K
20	6	R12, R28, R41, R44, R46, R53	10K
21	1	R13	220R/5W
22	3	R14, R15, R29	5k6
23	1	R18	0.5R/1%
24	10	R19, R20, R22, R23, R24, R30, R42, R45, R50, R52	100K
25	1	R21	82K
26	3	R25, R27, R55	1.0M
27	1	R26	470R
28	1	R43	100R
29	2	R47, R54	820R
30	2	R48, R49	270K
31	1	R51	2k7
32	1	F1	1A SLO-BLO
33	1	FH1	Fuse Holder
34	1	J1	Power Connector
35	3	J2, J3, J6	Phonejack
36	4	JW1, JW2, JW3, JW4	Phonejack Isolation Washer (if needed)
37	1	S1	SW SPDT
38	1	S2	SW SPST
39	1	S3	4P 3-Pos Rotary (Shorting)
40	1	S4	SW DPDT
41	2	D1, D2	UF4007
42	1	PL1	120V Pilot Lamp
43	1	T1	ChappellAmps Studio Power XFMR
44	1	T2	ChappellAmps Studio Output XFMR

45	1	L1	ChappellAmps Choke
46	4	SK1, SK4, SK6, SK7	9 Pin Tube Sockets
47	1	SK2	8 Pin Octal Socket
48	1	V1	EZ80/EZ81/6CA4
49	1	V2	6SN7GTB
50	1	V4	12AY7
51	2	V6, V7	12AX7
52	1	VR1	25KB (bias)
53	1	VR2	50KB
54	2	VR3, VR7	25KB
55	4	VR4, VR6, VR9, VR10	A1M
56	1	VR5	A250K
57	1	VR8	100KB
58	10	K1, K2, K3, K4, K5, K6, K7, K8, K9, K10	Knobs
59	1	CH1	Chassis
60	1	PWC1	Power Cord
61	1	TP1	Red Tip Jack
62	1	TP2	Black Tip Jack
63	1		3-lug Terminal Strip
64	1	O-PR-B	October Preamp Board
65	1	S-PA-B	Studio Poweramp Board
66	8		6-32 x 1/2" screws
67	8		#6 washers
68	8		#6 lock washers
69	8		6-32 nuts
70	2		ground lug
71	15		4-40 x 1/2" screws
72	20		#4 lock washers
73	20		4-40 nuts
74	5		1/2" standoffs
75	5		4-40 x 1/4" screws
76	5		7/16" ID rubber grommets
75		8'	blue wire
76		8'	black wire
77		5'	red wire
78		18" 22ga. & 12" 18ga.	green and white twisted wire
79		12"	black and red twisted wire
80		12"	yellow and red twisted wire
81		3'	lt. green
82		12"	lt.green and red twisted wire
83		3'	shielded wire
84		1/16" and 1/8"	heat shrink tubing

Note:

Wire colors may be substituted as noted.

Resistor values and wattage ratings may be substituted as noted.

Capacitor values and voltage ratings may be substituted as noted.

October Studio Options

Dual 6SN7 Option

1	2	R16, R17	5k6
2	1	R18	0.25R/1% (replaces 23 above)
3	1	V3	6SN7GTB (M&B with 49 above)
4	1	SK3	8 Pin Tube Socket
5	2		4-40 x 1/2" screws
6	2		#4 lock washers
7	2		4-40 nuts

FX Loop Option

1	1	C17	10uF/25V
2	1	C18	22uF/250V
3	1	C19	0.22uF/250V
4	1	C20	0.01uF/400V
5	1	R31	100K
6	1	R32	47K
7	1	R33	1K
8	4	R34, R36, R39, R40	1.0M
9	1	R35	100R
10	1	R37	820R
11	1	R38	22K
12	1	VR4	A25K (replaces VR4 above)
13	1	SK5	9 Pin Tube Socket
14	1	V5	12AT7
15	2	J4, J5	Phonejack
16	4	JW5, JW6, JW7, JW8	Phonejack Isolation Washer
17	2		4-40 x 1/2" screws
18	2		#4 lock washers
19	2		4-40 nuts

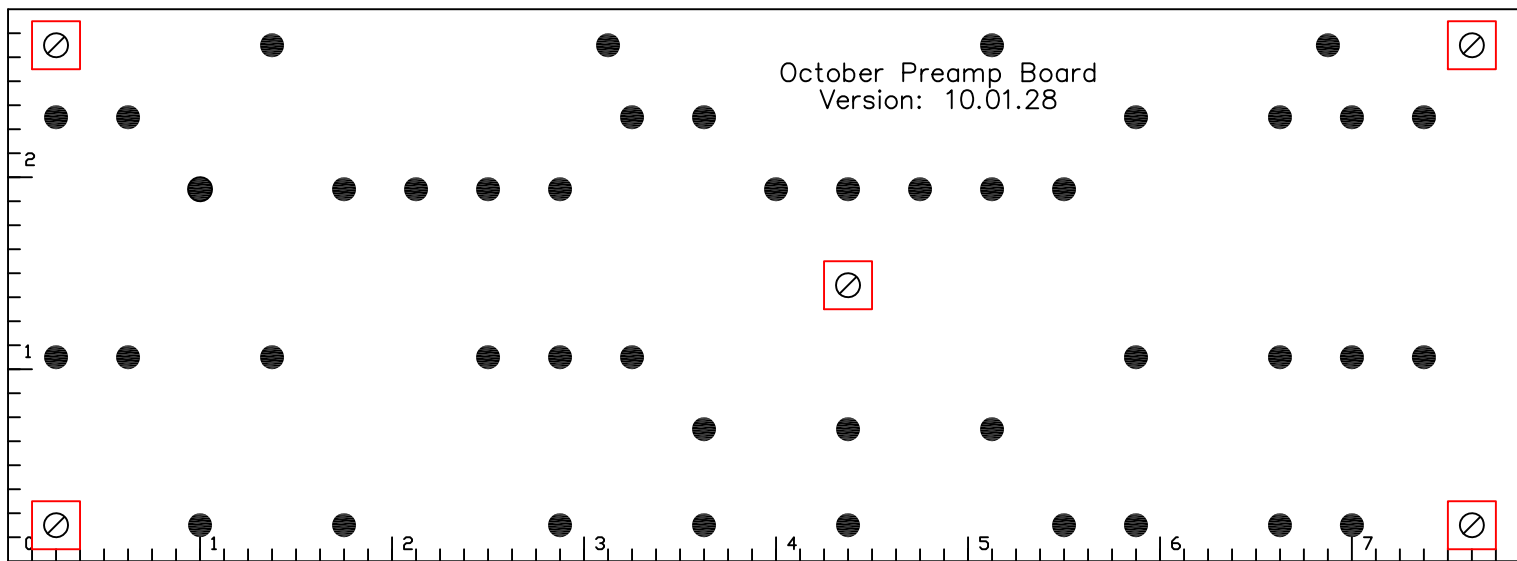
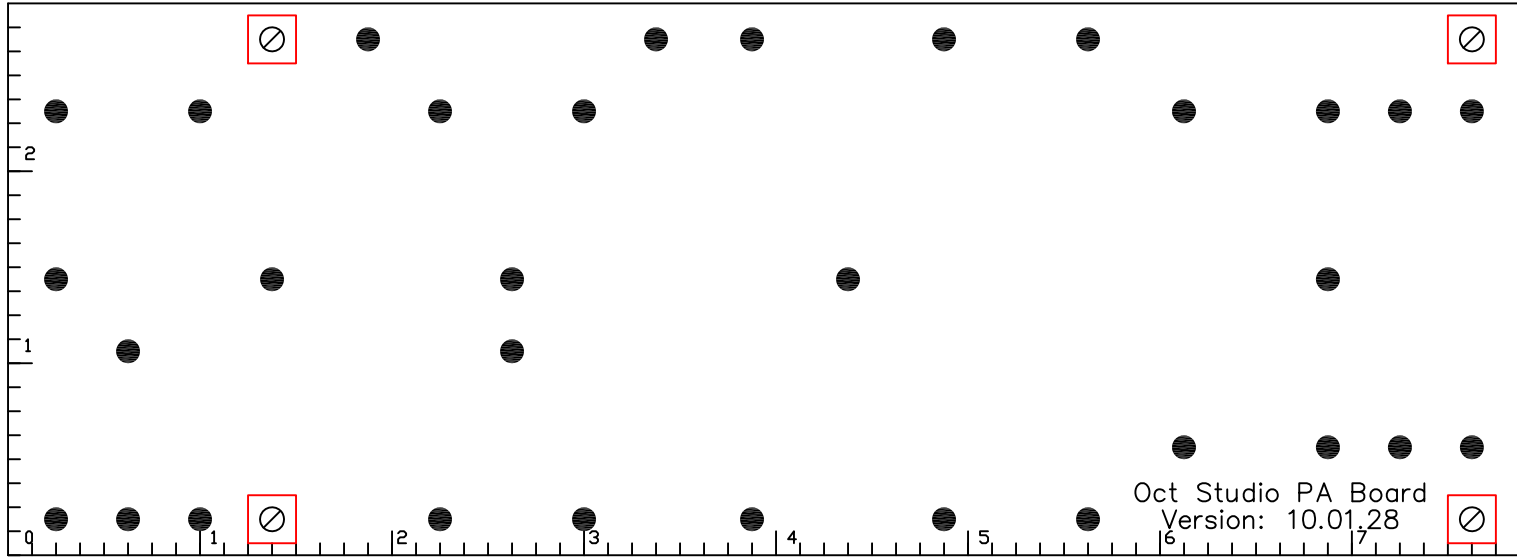

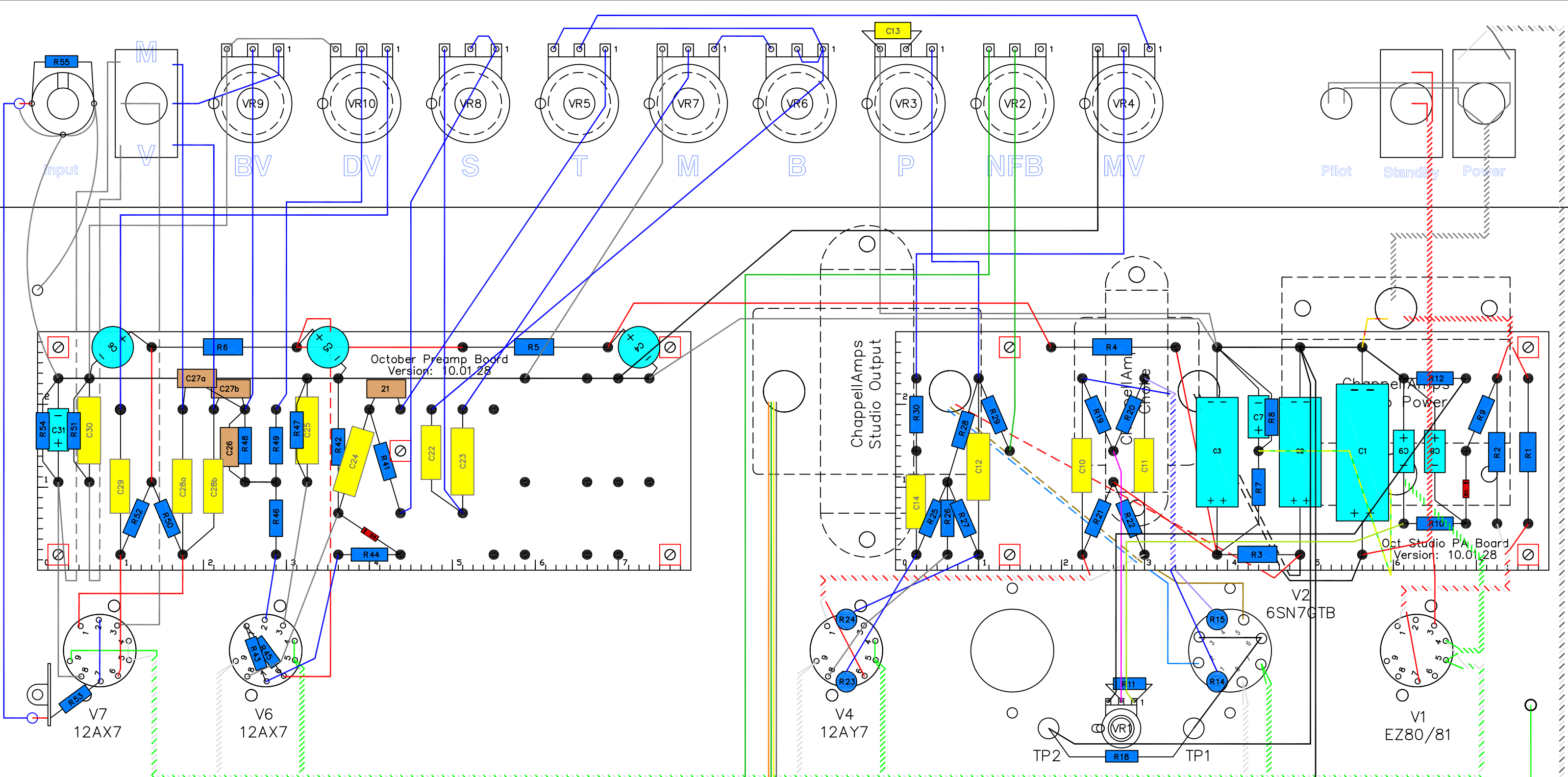

**ChappellAmps
October Studio Chassis Layout**
Version: 10.03.25

ChappellAmps Studio Kit Chassis
Version: 10.01.28

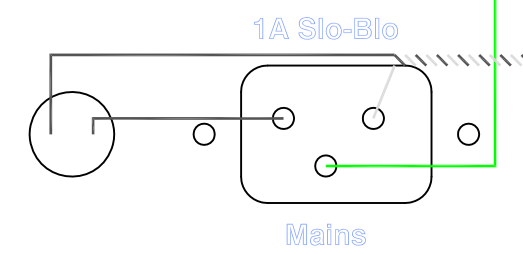
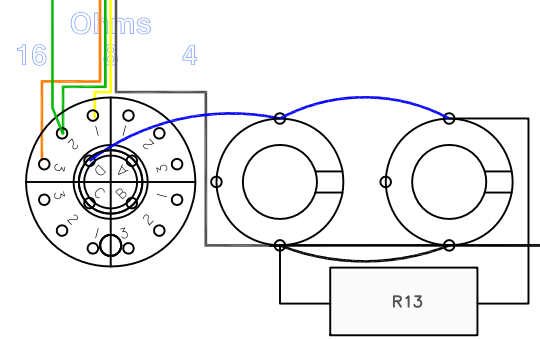
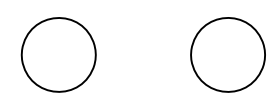

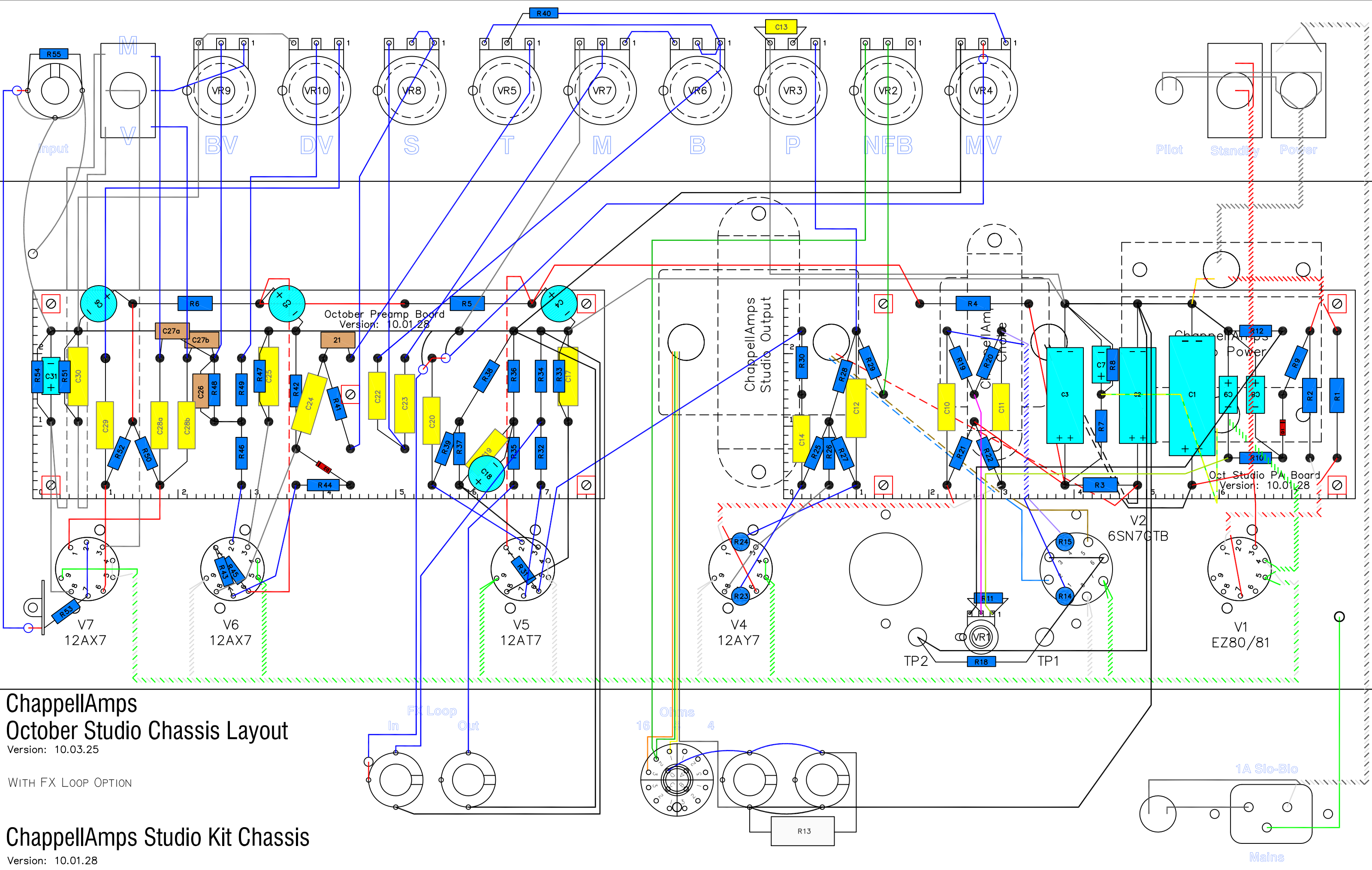

ChappellAmps
October Studio Chassis Layout
 Version: 10.03.25

WITH FX LOOP OPTION

ChappellAmps Studio Kit Chassis
 Version: 10.01.28

1A Slo-Blo

Mains

October Preamp Board
 Version: 10.01.28

ChappellAmps
 Studio Output

ChappellAmps
 Power

Oct Studio PA Board
 Version: 10.01.28

V2
 6SN7GTB

V7
 12AX7

V6
 12AX7

V5
 12AT7

V4
 12AY7

V1
 EZ80/81

In FX Loop

Out

16 Ohms

4

R13

Pilot Standby Power

Mains

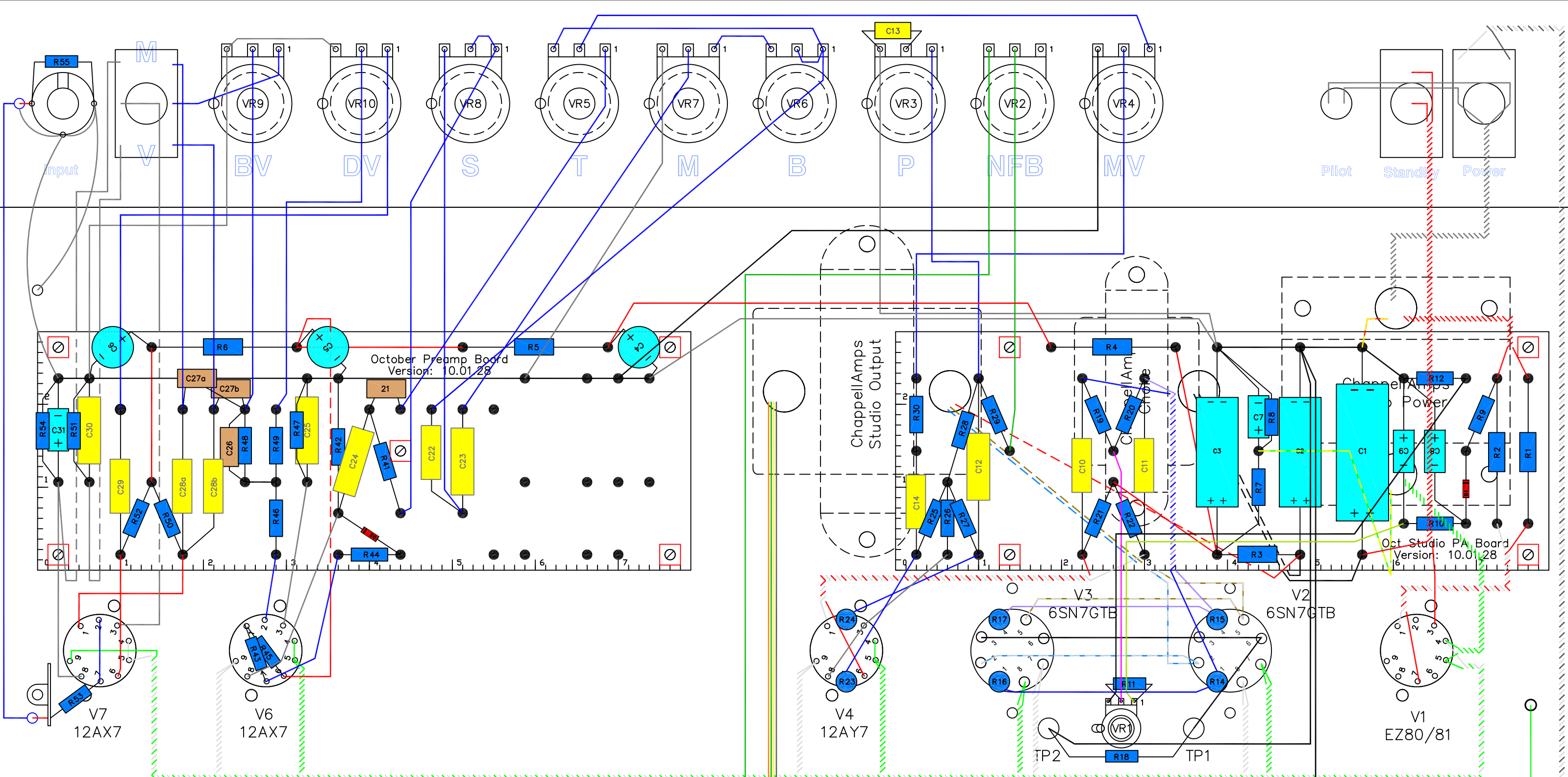

ChappellAmps October Studio Chassis Layout

Version: 10.03.25
WITH DUAL 6SN7 OPTION

ChappellAmps Studio Kit Chassis

Version: 10.01.28

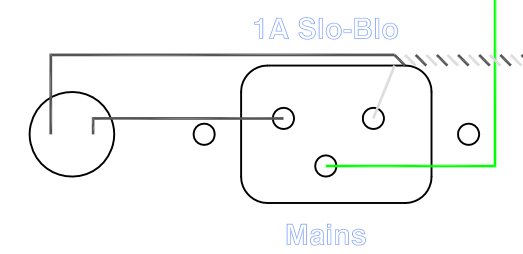
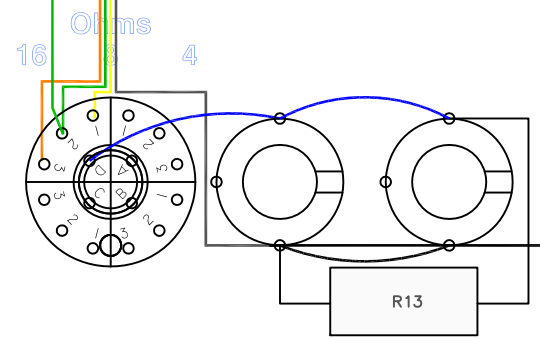
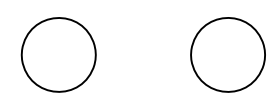

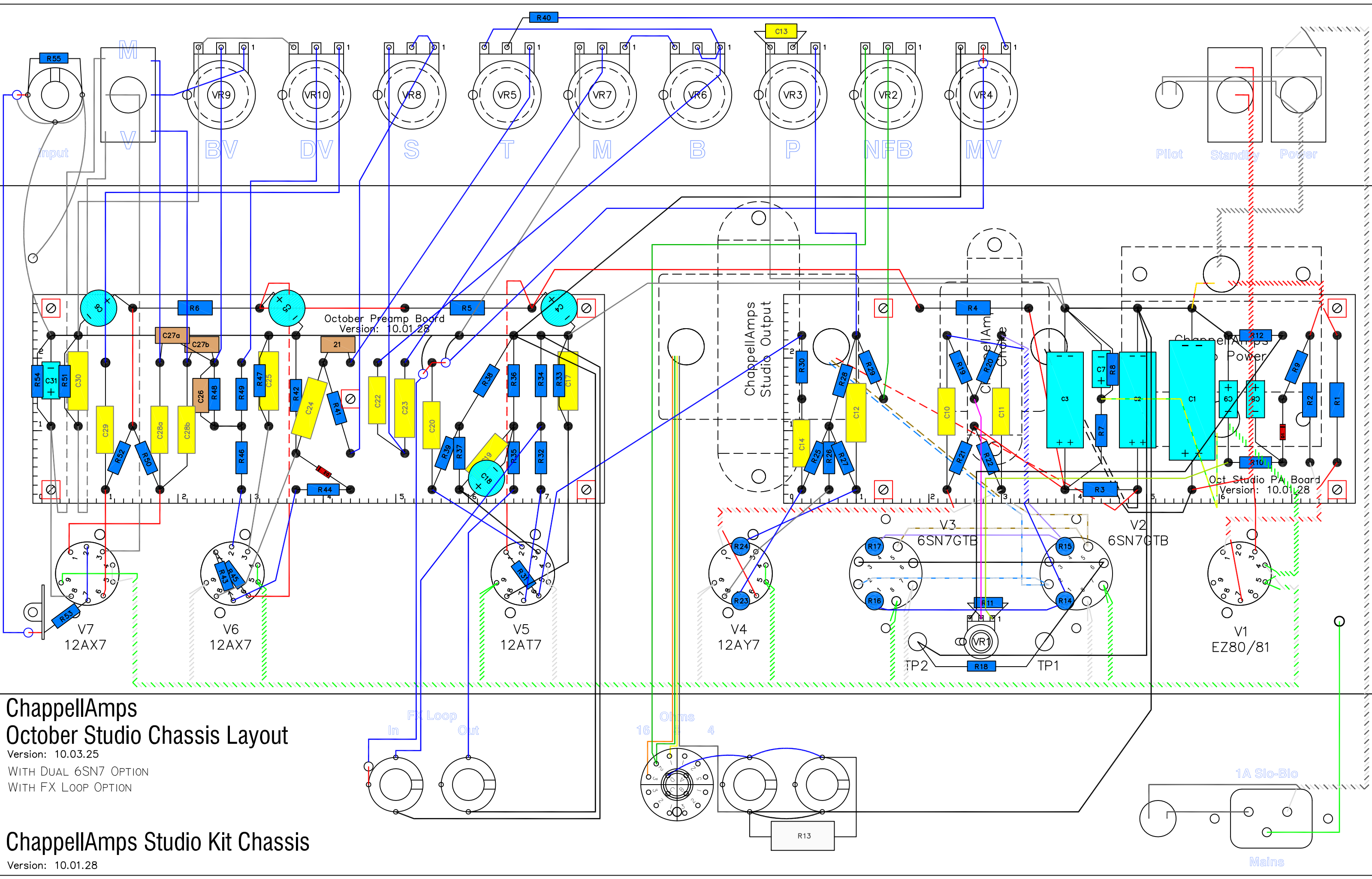

ChappellAmps October Studio Chassis Layout

Version: 10.03.25
 WITH DUAL 6SN7 OPTION
 WITH FX LOOP OPTION

ChappellAmps Studio Kit Chassis

Version: 10.01.28