

WARNING! - Please Read this Information Carefully:

The project described in these pages utilizes **POTENTIALLY FATAL HIGH VOLTAGES**. If you are in any way unfamiliar with high voltage circuits or are uncomfortable working around high voltages, **PLEASE DO NOT RISK YOUR LIFE BY BUILDING THEM**. Seek help from a competent technician before building any unfamiliar electronics circuit. While efforts are made to ensure accuracy of these circuits, no guarantee is provided, of any kind!

USE AT YOUR OWN RISK: THE WEBMASTER, PROJECT COORDINATOR, PROJECT CONTRIBUTORS AND WEB SPACE PROVIDER EXPRESSLY DISCLAIM ALL LIABILITY FOR INJURY OR PROPERTY DAMAGE RESULTING FROM THIS INFORMATION! ALL INFORMATION IS PROVIDED 'AS-IS' AND WITHOUT WARRANTY OF ANY KIND.

COPYRIGHT AND INTELLECTUAL PROPERTY NOTICE:

The content of this document is protected by the copyright laws of the United States of America and the international copyright laws and agreements.

Except where specifically noted, Cliff Chappell or Chris Hurley owns (or has permission to use) all intellectual property rights in relation to this document and its content (including, but not limited to, all trademarks and copyright).

No part of the document may be reproduced, displayed, copied, translated, adapted, downloaded, broadcast, used or republished in any form including (without limitation) distribution, or storage in a system for retrieval.

Revision	Description
08.04.25	Added Rx1 And Rx2 Changed Value of R14 And R15 To 82K Changed R23 To 470R And R25 To 10K Changed R26 To 10K
08.05.07	Changed VR3 To 50K LIN Change R28 To 5k6 Changed R20 And R21 To 250K Added R32, R33, And D2 To The CF Renumbered Components
08.05.19	Increased Voltage Rating On C6, C7, And C8 Changed R20, 21, 36 & 37 To Standard Value
08.05.21	Corrected Location of C13 On Chassis Layout Corrected C23 On Chassis Layout Relabled VR9 & VR10 On Chassis Layout

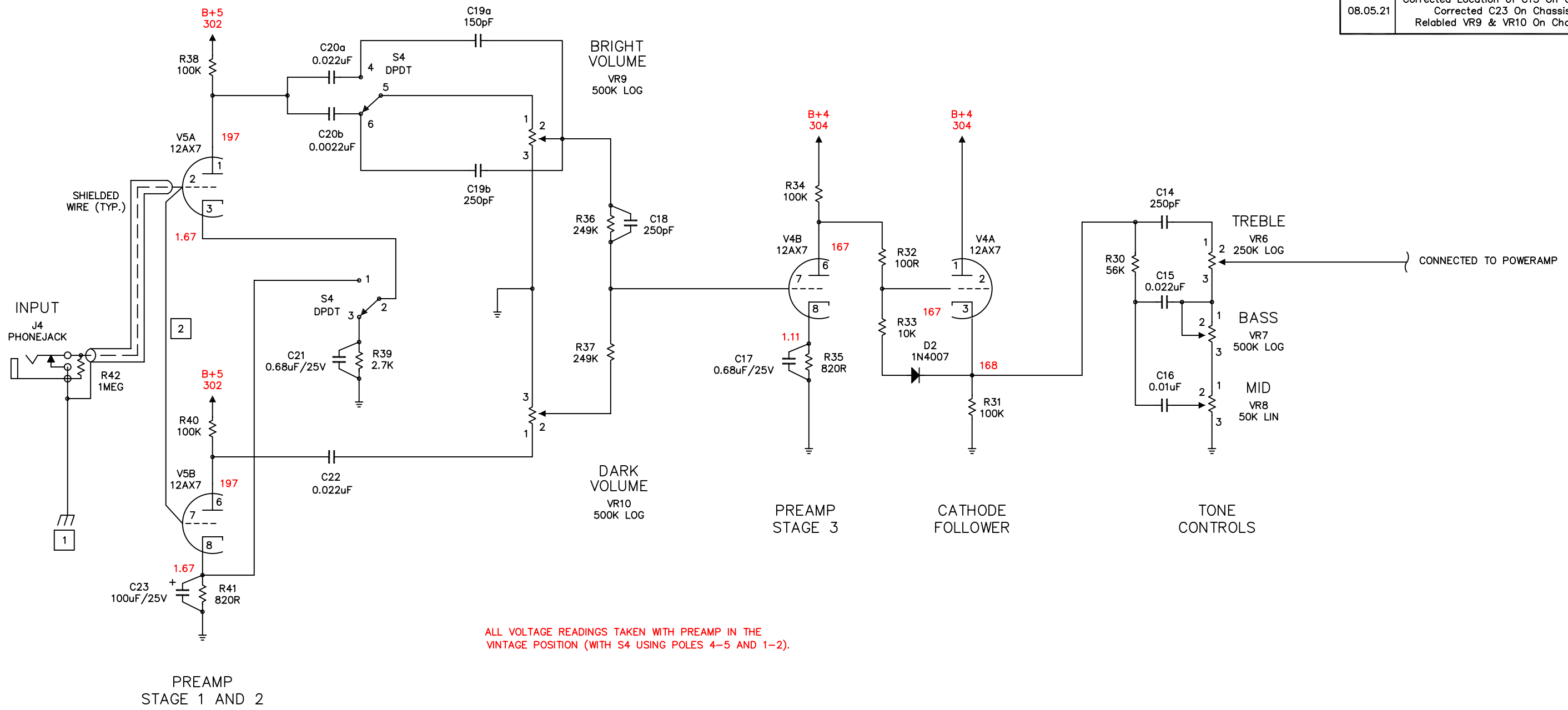

Revision	Description
08.04.25	Added Rx1 And Rx2 Changed Value of R14 And R15 To 82K Changed R23 To 470R And R25 To 10K Changed R26 To 10K
08.05.07	Changed VR3 To 50K LIN Change R28 To 5k6 Changed R20 And R21 To 250K Added R32, R33, And D2 To The CF Renumbered Components
08.05.19	Increased Voltage Rating On C6, C7, And C8 Changed R20, 21, 36 & 37 To Standard Value
08.05.21	Corrected Location of C13 On Chassis Layout Corrected C23 On Chassis Layout Relabelled VR9 & VR10 On Chassis Layout

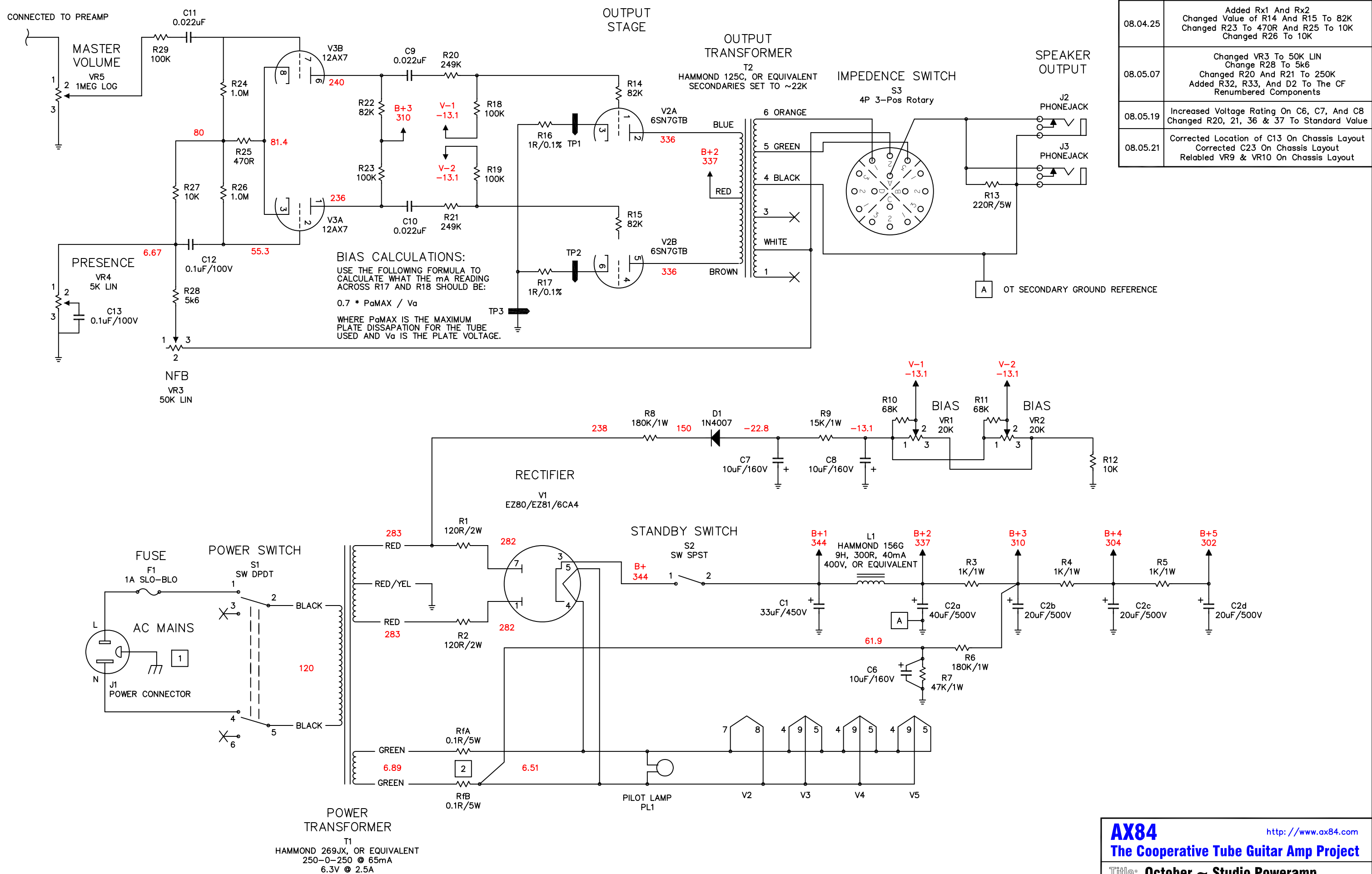

BIAS CALCULATIONS:
 USE THE FOLLOWING FORMULA TO
 CALCULATE WHAT THE mA READING
 ACROSS R17 AND R18 SHOULD BE:
 $0.7 * P_{aMAX} / V_a$
 WHERE P_{aMAX} IS THE MAXIMUM
 PLATE DISSIPATION FOR THE TUBE
 USED AND V_a IS THE PLATE VOLTAGE.

Revision	Description
08.04.25	Added Rx1 And Rx2 Changed Value of R14 And R15 To 82K Changed R23 To 470R And R25 To 10K Changed R26 To 10K
08.05.07	Changed VR3 To 50K LIN Change R28 To 5k6 Changed R20 And R21 To 250K Added R32, R33, And D2 To The CF Renumbered Components
08.05.19	Increased Voltage Rating On C6, C7, And C8 Changed R20, 21, 36 & 37 To Standard Value
08.05.21	Corrected Location of C13 On Chassis Layout Corrected C23 On Chassis Layout Relabelled VR9 & VR10 On Chassis Layout

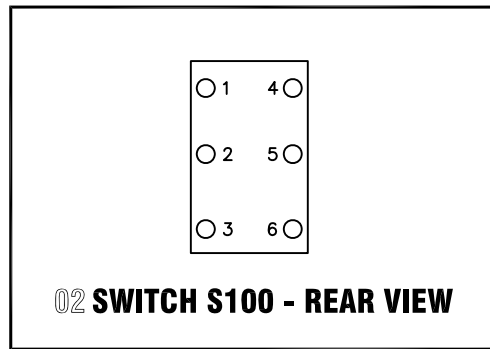
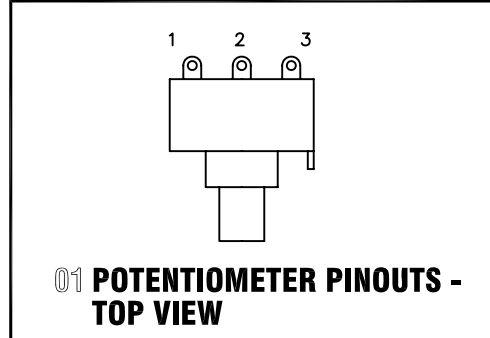

GENERAL NOTES:

1. ALL RESISTORS 1/2W MINIMUM UNLESS OTHERWISE NOTED.
2. ALL COUPLING CAPACITORS 400V OR GREATER.
3. VOLTAGE READINGS ARE THOSE TAKEN WITH MY TUBE SET. THE USE OF DIFFERENT TUBE SETS WILL ALTER THE READINGS.

CONSTRUCTION NOTES:

- 1 THIS IS A GROUND CONNECTION TO THE CHASSIS. THE MAINS SAFETY CONNECTION SHOULD BE MADE AS CLOSE AS POSSIBLE TO THE POINT WHERE AC ENTERS THE CHASSIS. THE CIRCUIT CONNECTION SHOULD BE MADE AS CLOSE AS POSSIBLE TO THE INPUT JACK. IDEALLY, THE JACK ITSELF SHOULD BE USED AS THE CONNECTION POINT BY NOT ISOLATING IT FROM THE CHASSIS.
- 2 THESE TWO 0.1R/5W RESISTORS ARE OPTIONAL, AND ARE NEEDED ONLY WHEN YOUR MAINS VOLTAGES ARE GREATER THAN THAT WHICH THE POWER TRANSFORMER WAS WOUND FOR. THE VALUES SHOWN SHOULD BE CORRECT FOR A 115V PT USED WITH 120V MAINS. THE PURPOSE OF THESE TWO RESISTORS IS TO INSURE THAT THE FILAMENT VOLTAGE STAYS WITHIN +/- 10% OF 6.3VAC.

VOLTAGE READING NOTES:

1. THE VOLTAGE READINGS ON THIS SCHEMATIC ARE SIMULATED BASED ON THE USE OF A HAMMOND 269JX WITH 120V MAINS.
2. DIFFERENT TUBES DRAW DIFFERENT AMOUNTS OF CURRENT, NO TWO ARE ALIKE UNLESS THEY ARE MATCHED. THE AMOUNT OF CURRENT DRAWN BY ALL THE TUBES IN THE AMP WILL AFFECT VOLTAGE READINGS THROUGHOUT THE AMP.

AX84 October Studio Amplifier BOM

Revision: 08.05.21

NOTE: Parts for options are not included on this bill of materials.

Item	Quantity	Reference	Value
1	1	C1	33uF/450V
2	1	C2	40/20/20/20 Multi-section Capacitor
3	3	C6, C7, C8	10uF/160V
4	6	C9, C10, C11, C15, C20a, C22	0.022uF/400V
5	2	C12, C13	0.1uF/100V
6	3	C14, C18, C19b	250pF/500V
7	1	C16	0.01uF/400V
8	2	C17, C21	0.68uF/25V
9	1	C19a	150pF/500V
10	1	C20b	0.0022uF/400V
11	1	C23	100uF/25V
12	2	R1, R2	120R/2W
13	2	Rfa, Rfb	0.1R/5W
14	3	R3, R4, R5	1K/1W
15	2	R6, R8	180K/1W
16	1	R7	47K/1W
17	1	R9	15K/1W
18	2	R10, R11	68K
19	3	R12, R27, R33	10K
20	1	R13	220R/5W
21	3	R14, R15, R22	82K
22	2	R16, R17	1R/0.1%
23	8	R18, R19, R23, R29, R31, R34, R38, R40	100K
24	4	R20, R21, R36, R37	249K
25	3	R24, R26, R42	1.0M
26	1	R25	470R
27	1	R28	5k6
28	1	R30	56K
29	1	R32	100R
30	1	R35, R41	820R
31	1	R39	2k7
34	1	F1	1A SLO-BLO
35	1	FH1	Fuse Holder
36	1	J1	Power Connector
37	3	J2, J3, J4	Phonejack
38	4	JW1, JW2, JW3, JW4	Phonejack Isolation Washer (if needed)
39	1	S1	SW DPDT
40	1	S2	SW SPST
41	1	S3	4P 3-Pos Rotary (Shorting)
42	2	D1, D2	1N4007
43	1	PL1	Pilot Lamp Assembly And Bulb
44	1	T1	Hammond 269JX
45	1	T2	Hammond 125C

46	1	L1	Hammond 156G
47	4	SK1, SK3, SK4, SK5	9 Pin Tube Sockets
48	1	SK2	8 Pin Octal Socket
49	1	V1	EZ80/EZ81/6CA4
50	1	V2	6SN7GTB
51	3	V3, V4, V5	12AX7
52	2	VR1, VR2	20K LIN
53	2	VR3, VR8	50K LIN
54	1	VR4	5K LIN
55	1	VR5	1MEG LOG
56	1	VR6	250K LOG
57	3	VR7, VR9, VR10	500K LOG
59	1	CCImp	Clamp For Multi-section Cap C2
60	8	K1, K2, K3, K4, K5, K6, K7, K8	Knobs
61	1	CH1	Chassis

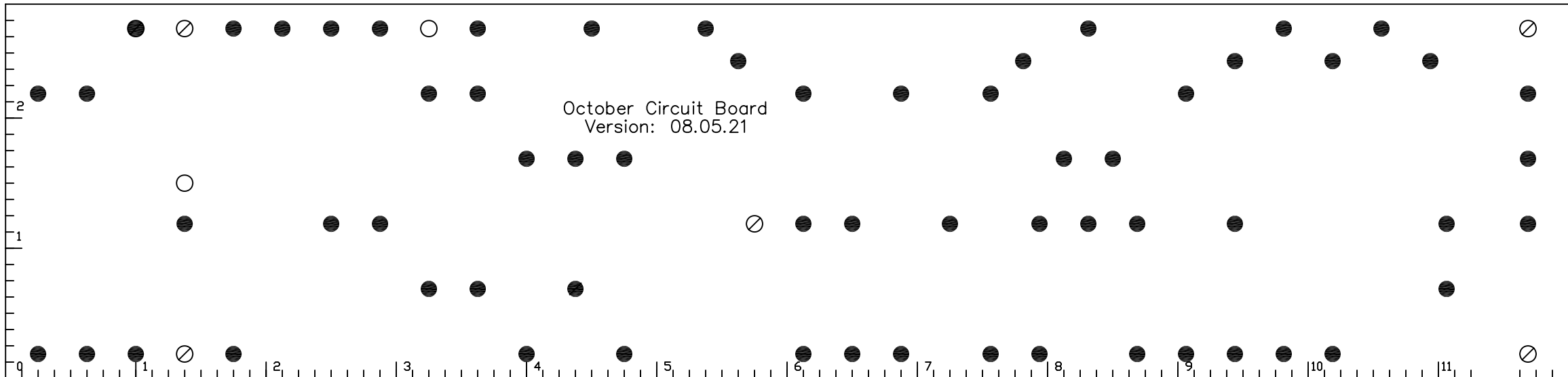

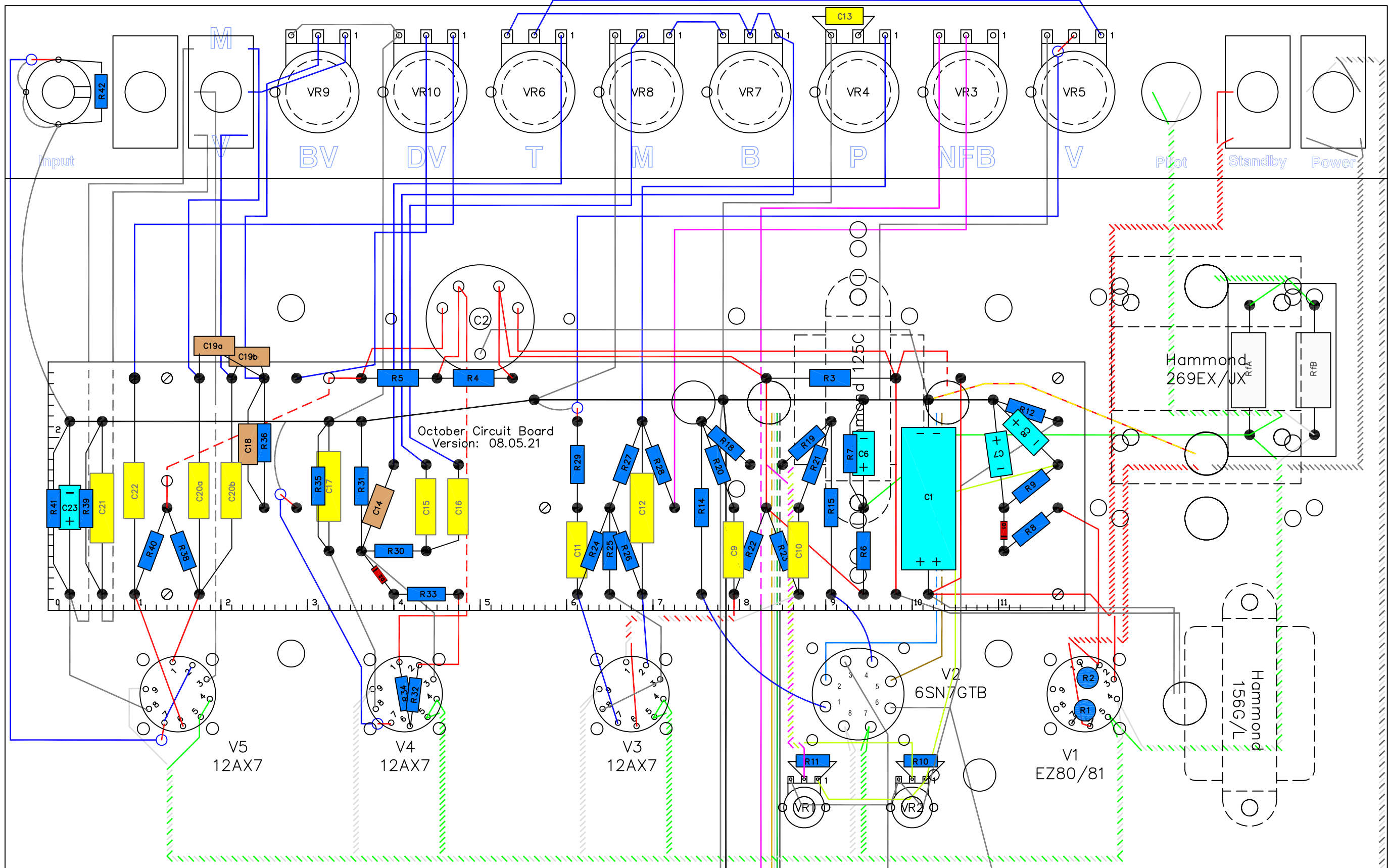

AX84 October ~ Studio Chassis Layout

Version: 08.05.21

AX84 Kit Chassis 1

Version: 08.05.07

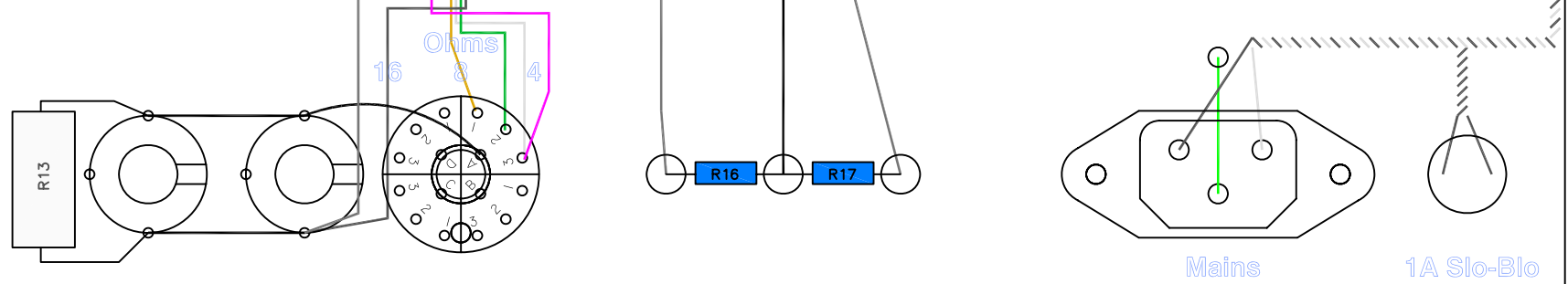

Mains 1A Slo-Blo