

The High-Octane Options Guide

10.10.04

Hours of fun and frustration with your AX84 amp.

WARNING! - Please Read this Information Carefully:

The project described in these pages utilizes **POTENTIALLY FATAL HIGH VOLTAGES**. If you are in any way unfamiliar with high voltage circuits or are uncomfortable working around high voltages, **PLEASE DO NOT RISK YOUR LIFE BY BUILDING THEM**. Seek help from a competent technician before building any unfamiliar electronics circuit. While efforts are made to ensure accuracy of these circuits, no guarantee is provided, of any kind!

USE AT YOUR OWN RISK: THE WEBMASTER, PROJECT COORDINATOR, PROJECT CONTRIBUTORS AND WEB SPACE PROVIDER EXPRESSLY DISCLAIM ALL LIABILITY FOR INJURY OR PROPERTY DAMAGE RESULTING FROM THIS INFORMATION! ALL INFORMATION IS PROVIDED 'AS-IS' AND WITHOUT WARRANTY OF ANY KIND.

COPYRIGHT AND INTELLECTUAL PROPERTY NOTICE:

The content of this document is protected by the copyright laws of the United States of America and the international copyright laws and agreements.

Except where specifically noted, Cliff Chappell or Chris Hurley owns (or has permission to use) all intellectual property rights in relation to this document and its content (including, but not limited to, all trademarks and copyright).

No part of the document may be reproduced, displayed, copied, translated, adapted, downloaded, broadcast, used or republished in any form including (without limitation) distribution, or storage in a system for retrieval.

The Variable Cathode Bias Option

This is a modification that can be made to cathode biased amps like the P1, High Octane, P1 eXtreme, and the SEL. In fact, I make this mod to all of the SE amps I build. By adding one 1K Linear potentiometer, one 1R – 5% resistor, two multi-meter probe test points, changing the existing cathode resistor to a 100R/5W unit, and adding a little wire, you can give yourself the ability to dial in the bias setting you want for any output tube you care to use.

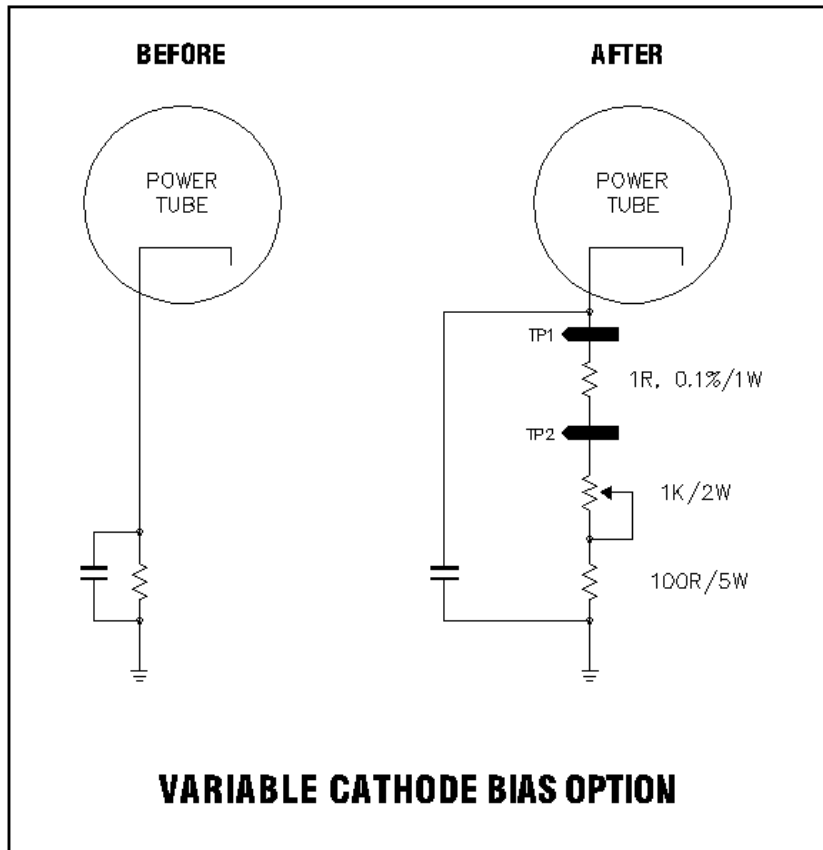

The 5% 1R resistor (you can use a 10% resistor, but the more accurate your resistor, the more accurate your reading), is placed between the two test points. You will use your multi-meter, set to mV, to measure the voltage across the 1R resistor. Since the resistor is 1R, V = mA of current that the tube is drawing.

To set the bias, first insert the positive probe in TP1 and the negative in TP2, and change the dial to mV. Pay attention to the meter. When you dial the pot one way, current (mV) increases. When you dial it the other way, current (mV) decreases. Dial the pot so that the mV reading is as low as it will go.

Now, take a reading of the anode (aka plate) voltage and use the following formula to determine the bias setting for the tube you are using: $(PaMax * 0.9) / Va$

PaMax is the maximum plate dissipation of the tube you are using and Va is the voltage at the anode that you measured. Once you have that number, you simply adjust the bias pot until you see that number on the display.

Parallel Octal Output Tube Option

This is a great option for those builders who want to add the tonal varieties available with octal output tubes to their P1 or High Octane amp.

WARNING: You can only use this option in P1's and HO's. Do not attempt to use EL84's in SE amps that have a B+ plate voltage greater than 275V. Do not attempt to use both tubes at the same time with the stock Hammond 269EX. You will exceed its current rating.

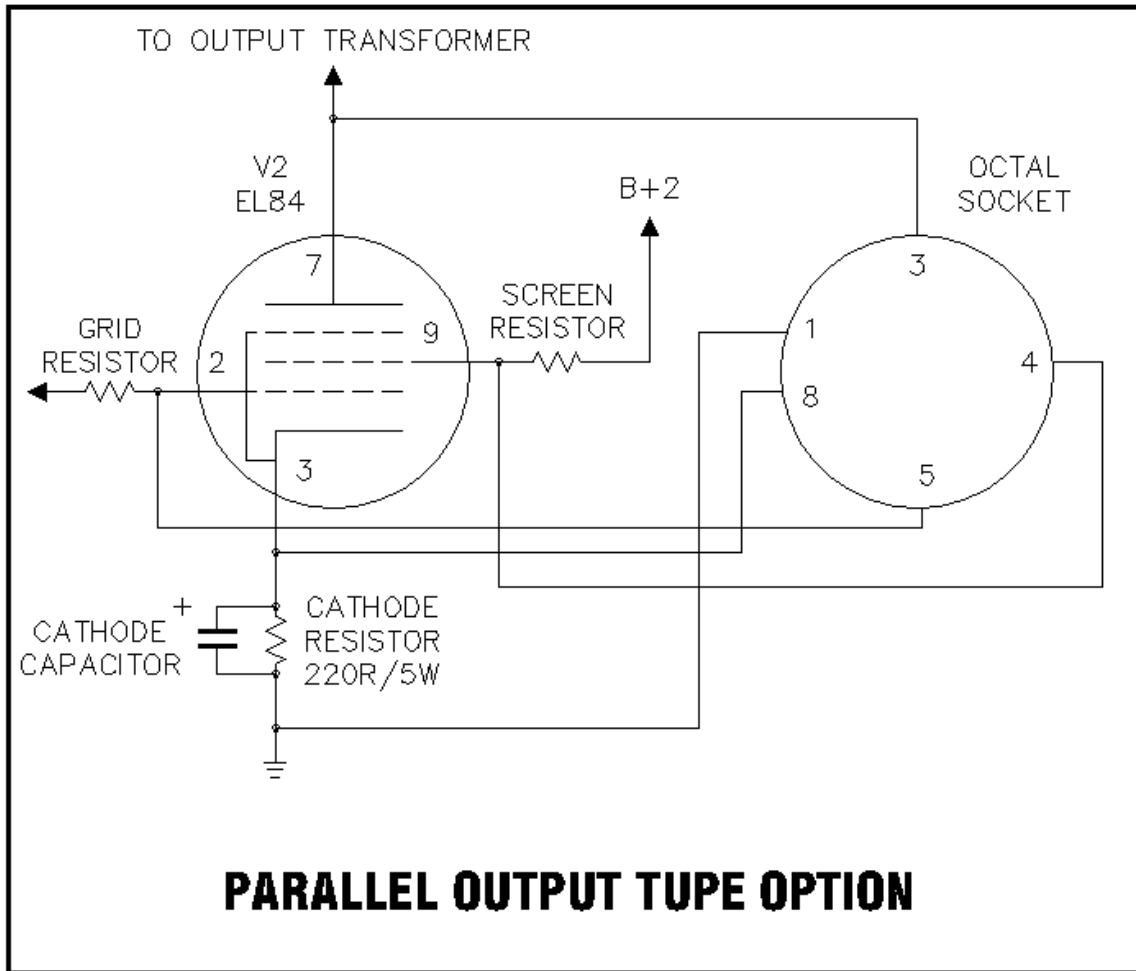

Lead dress is a very important issue with this option. You will have to pay special attention to wire routing. It is **HIGHLY** recommended that you install both sockets, wire up the filaments to both sockets, but that you connect and debug the EL84 tube **FIRST**. Get the amp working like that and make sure you don't have hum, buzz, or squealing problems. If you do, get them resolved **BEFORE** you wire up the remaining connections for the octal socket. If you do that and get squeals or other problems after adding the octal connections, then you know it's one, or more, of the wires you added that is causing the problem.

Low-watt Output Option

Here is an option for those who find out, like most folks do, that a 5W amp is a lot louder than you thought it would be. Installing a 6n1P triode as an output tube lowers to power out to about 1W. For even lower output, you could just use one half instead of both as shown here.

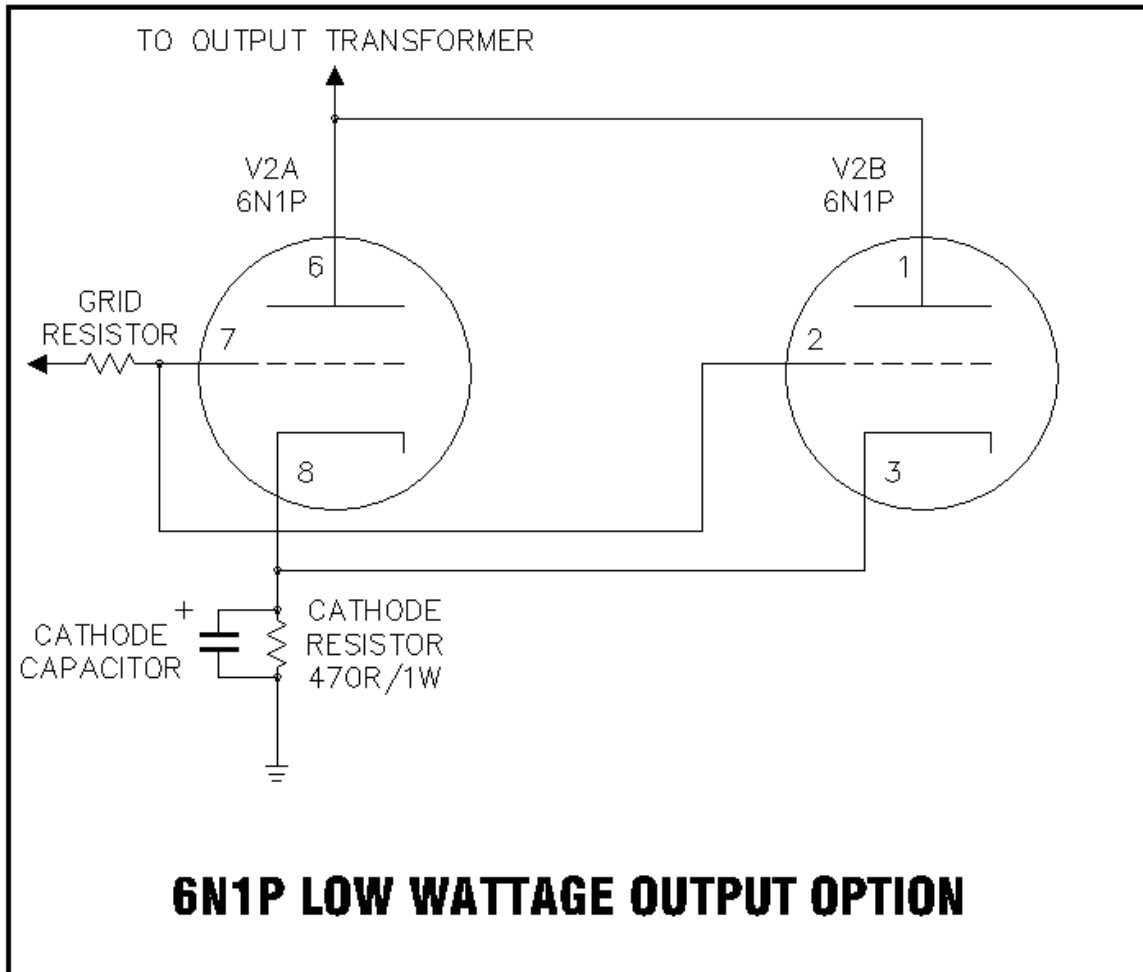

NOTE: If you install this option, be sure and change the cathode resistor to a 470R/1W unit!

The Lead/Rhythm Switch

This option is one I like to install on all of the High Octane's and SEL's that I build. For just the cost of a SPDT switch, you can change between high and low gain settings. In the Rhythm mode the amp is capable of all of the tonal variations of the P1 and P1 Extreme. In fact, because the cathode follower is left in the circuit in both modes, the volume only changes about as much as you would ideally want between lead and rhythm, so you don't need two volume controls.

