

## **WARNING! - Please Read this Information Carefully:**

The project described in these pages utilizes **POTENTIALLY FATAL HIGH VOLTAGES**. If you are in any way unfamiliar with high voltage circuits or are uncomfortable working around high voltages, **PLEASE DO NOT RISK YOUR LIFE BY BUILDING THEM**. Seek help from a competent technician before building any unfamiliar electronics circuit. While efforts are made to ensure accuracy of these circuits, no guarantee is provided, of any kind!

***USE AT YOUR OWN RISK:*** THE WEBMASTER, PROJECT COORDINATOR, PROJECT CONTRIBUTORS AND WEB SPACE PROVIDER EXPRESSLY DISCLAIM ALL LIABILITY FOR INJURY OR PROPERTY DAMAGE RESULTING FROM THIS INFORMATION! ALL INFORMATION IS PROVIDED 'AS-IS' AND WITHOUT WARRANTY OF ANY KIND.

## **COPYRIGHT AND INTELLECTUAL PROPERTY NOTICE:**

The content of this document is protected by the copyright laws of the United States of America and the international copyright laws and agreements.

Except where specifically noted, Cliff Chappell or Chris Hurley owns (or has permission to use) all intellectual property rights in relation to this document and its content (including, but not limited to, all trademarks and copyright).

No part of the document may be reproduced, displayed, copied, translated, adapted, downloaded, broadcast, used or republished in any form including (without limitation) distribution, or storage in a system for retrieval.

Revision	Description
08.10.22	Made The Standby Switch Optional
08.11.10	Public Release
08.11.15	Corrected OT Wiring Colors
10.02.16	Corrections To The Chassis Layout

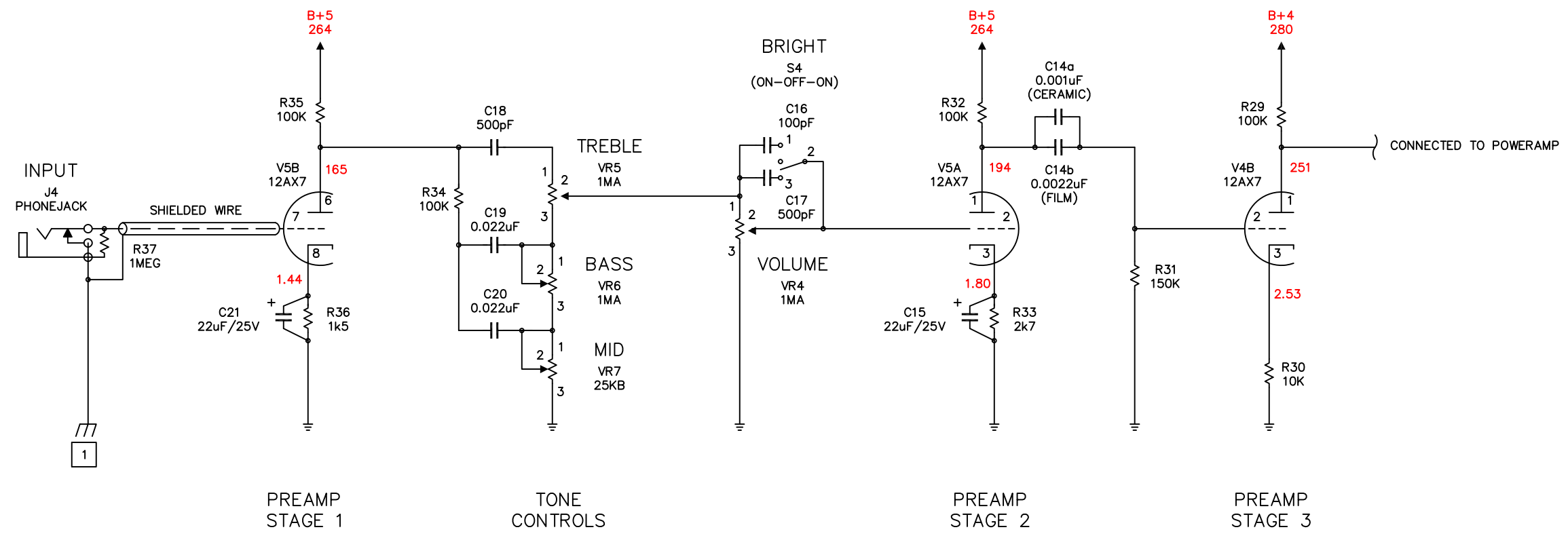



Revision	Description
08.10.22	Made The Standby Switch Optional
08.11.10	Public Release
08.11.15	Corrected OT Wiring Colors
10.02.16	Corrections To The Chassis Layout

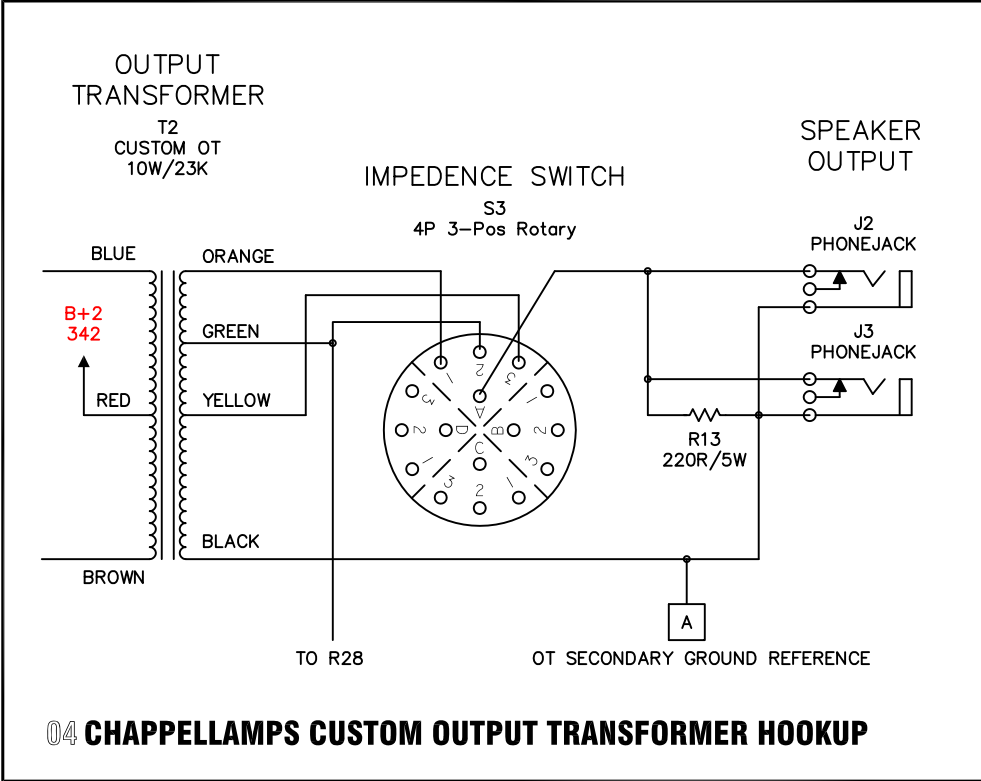
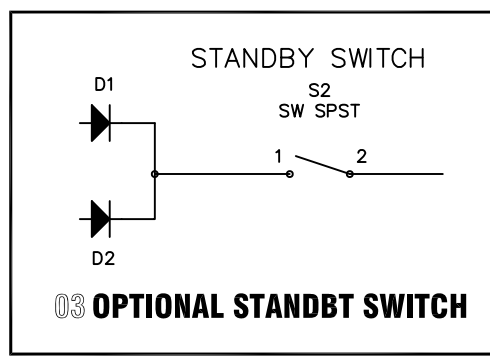
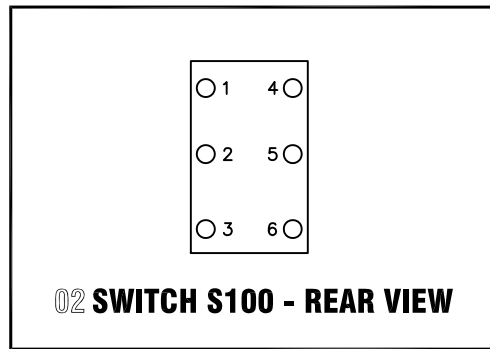
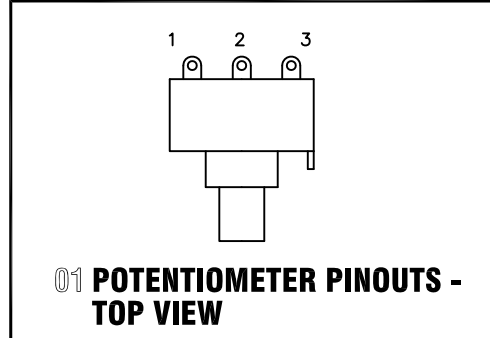

**GENERAL NOTES:**

1. ALL RESISTORS 1/2W MINIMUM UNLESS OTHERWISE NOTED.
2. ALL COUPLING CAPACITORS 400V OR GREATER.
3. VOLTAGE READINGS ARE THOSE TAKEN WITH MY TUBE SET. THE USE OF DIFFERENT TUBE SETS WILL ALTER THE READINGS.
4. THE  SYMBOL REPRESENTS SHIELDED CABLE.

**CONSTRUCTION NOTES:**

- 1 THIS IS A GROUND CONNECTION TO THE CHASSIS. THE MAINS SAFETY CONNECTION SHOULD BE MADE AS CLOSE AS POSSIBLE TO THE POINT WHERE AC ENTERS THE CHASSIS. THE CIRCUIT CONNECTION SHOULD BE MADE AS CLOSE AS POSSIBLE TO THE INPUT JACK. IDEALLY, THE JACK ITSELF SHOULD BE USED AS THE CONNECTION POINT BY NOT ISOLATING IT FROM THE CHASSIS.
- 2 THESE TWO 0.1R/5W RESISTORS ARE OPTIONAL, AND ARE NEEDED ONLY WHEN YOUR MAINS VOLTAGES ARE GREATER THAN THAT WHICH THE POWER TRANSFORMER WAS WOUND FOR. THE VALUES SHOWN SHOULD BE CORRECT FOR A 115V PT USED WITH 120V MAINS. THE PURPOSE OF THESE TWO RESISTORS IS TO INSURE THAT THE FILAMENT VOLTAGE STAYS WITHIN +/- 10% OF 6.3VAC.

**VOLTAGE READING NOTES:**

1. THE VOLTAGE READINGS ON THIS SCHEMATIC ARE SIMULATED BASED ON THE USE OF A HAMMOND 269JX WITH 120V MAINS.
2. DIFFERENT TUBES DRAW DIFFERENT AMOUNTS OF CURRENT, NO TWO ARE ALIKE UNLESS THEY ARE MATCHED. THE AMOUNT OF CURRENT DRAWN BY ALL THE TUBES IN THE AMP WILL AFFECT VOLTAGE READINGS THROUGHOUT THE AMP.

**TUNING NOTES:**

1. A 12AV7 TUBE MAY BE USED IN THE V3 POSITION TO LOWER THE GAIN OF THE PI AND REDUCE DISTORTION.
2. A 12AY7 MAY BE USED IN THE V5 POSITION TO LOWER THE GAIN AND OVERALL DISTORTION OF THE AMP.
3. YOU WILL FIND THAT TWO IMPORTANT AREA FOR TUNING THIS AMP IS THE COUPLING CAPACITOR(S) AND GRID RESISTOR BETWEEN THE 2ND AND 3RD PREAMP STAGES. LOWERING THE VALUE OF R31 WILL REDUCE THE DISTORTION, AND CHANGING C14A/B WILL AFFECT BASS AND TREBLE RESPONSE.

# AX84 4-4-0 Studio Amplifier BOM

Revision: 10.02.16

NOTE: Parts for options are not included on this bill of materials.

Item	Quantity	Reference	Value
1	1	C1	100uF/450V
2	1	C2	40/20/20/20 Multi-section Capacitor
3	3	C6, C7, C8	10uF/160V
4	4	C9, C10, C19, C20	0.022uF/400V
5	1	C11	0.1uF/400V
6	1	C12	0.1uF/100V
7	1	C13	0.68uF/100
8	1	C14a	0.001uF/1KVA (ceramic)
9	1	C14b	0.0022uF/400V (film)
10	2	C15, C21	22uF/25V
11	1	C16	100pF/500V
12	2	C17, C18	500pF/500V
13	1	R2	1K/5W
14	2	Rfa, Rfb	0.1R/5W
15	1	R3	6k8/1W
16	1	R4	12K/1W
17	1	R5	10K/1W
18	2	R6, R8	180K/1W
19	1	R7	47K/1W
20	1	R9	15K/1W
21	2	R10, R11	68K
22	3	R12, R27, R30	10K
23	1	R13	220R/5W
24	1	R14, R15, R28	5k6
25	1	R22	82K
26	2	R16, R17	1R/1%
27	7	R18, R19, R23, R29, R32, R34, R35	100K
28	2	R20, R21	Not Used
29	3	R24, R26, R37	1.0M
30	1	R25	470R
31	1	R31	150K
32	1	R33	2k7
33	1	R36	1k5
34	1	F1	1A SLO-BLO
35	1	FH1	Fuse Holder
36	1	PWC1	Power Cord
37	1	J1	Power Connector
38	3	J2, J3, J4	Phonejack
39	4	JW1, JW2, JW3, JW4	Phonejack Isolation Washer (if needed)
40	1	S1	SW DPDT
41	1	S3	4P 3-Pos Rotary (Shorting)
42	1	S4	SW SPDT (ON-OFF-ON)
43	3	D1, D2, D3	UF4007
44	1	PL1	Pilot Lamp Assembly And Bulb

45	1	T1	Hammond 269JX
46	1	T2	Hammond 125C
47	3	SK3, SK4, SK5	9 Pin Tube Sockets
48	1	SK2	8 Pin Octal Socket
49	1	V2	6SN7GTB
50	1	V3	12AY7
51	2	V4, V5	12AX7
52	2	VR1, VR2	25KB (bias pots)
53	2	VR3, VR7	25KB
54	3	VR4, VR5, VR6	1MA
55	1	CCImp	Clamp For Multi-section Cap C2
56	5	K1, K2, K3, K4, K5	Knobs
57	1	CH1	Chassis
58	2	TP1, TP2	Red Tip Jack
59	1	TP3	Black Tip Jack
60	2		3-lug terminal strip

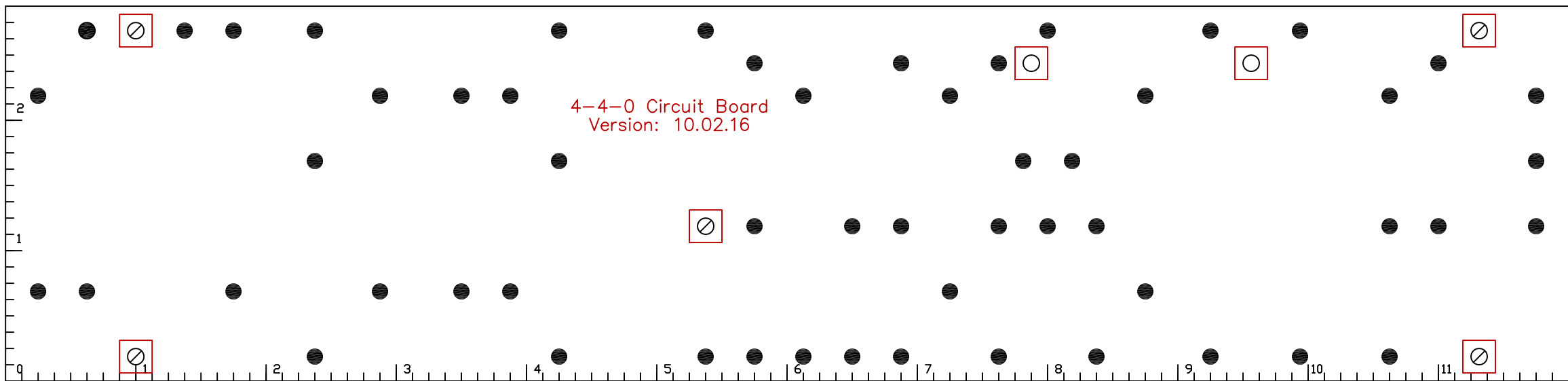

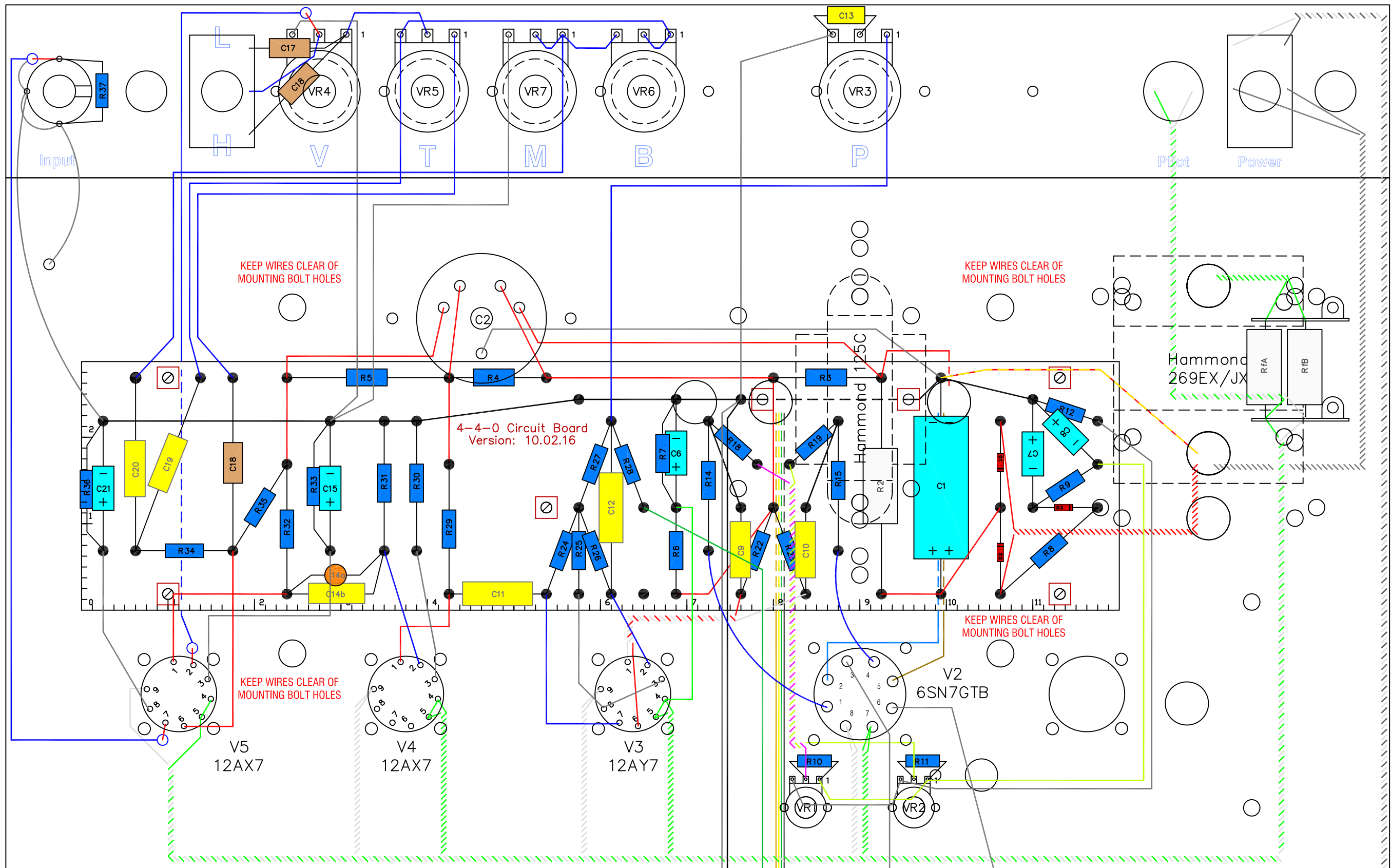

# AX84 4-4-0 ~ Studio Chassis Layout

Version: 10.02.16

## AX84 Kit Chassis 1

Version: 08.05.07

